

8 7 6 5 4 3 2 1

D  
C  
B  
A

D  
C  
B  
A

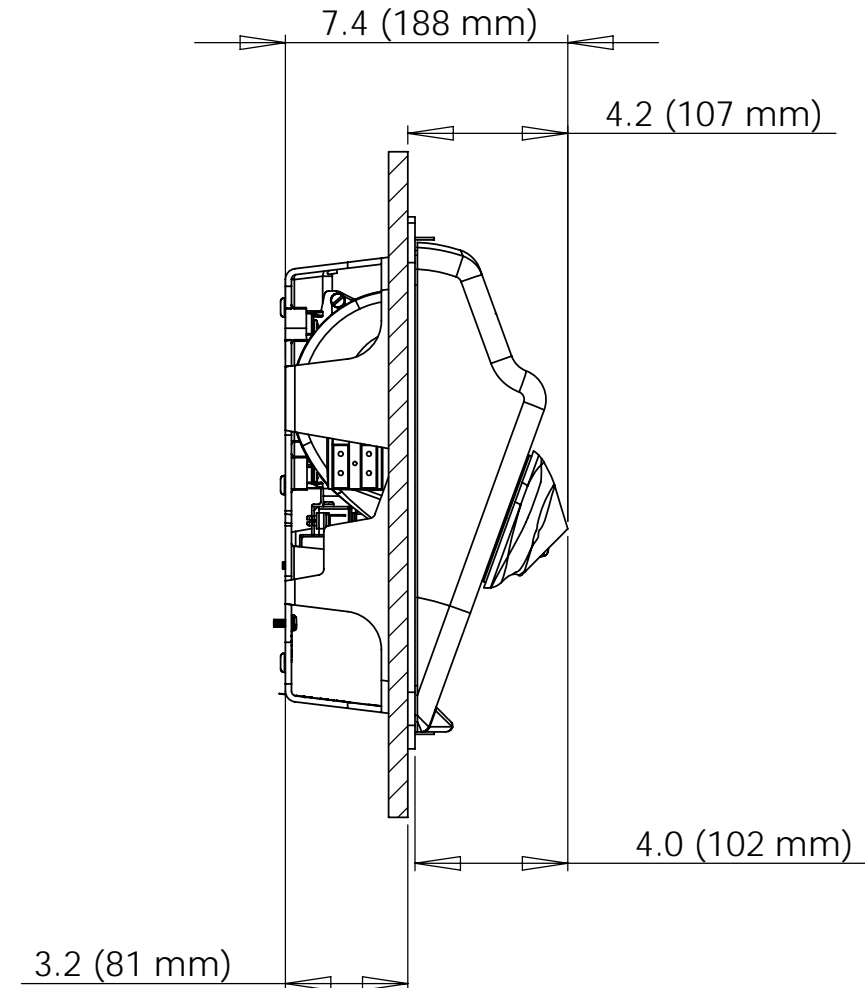
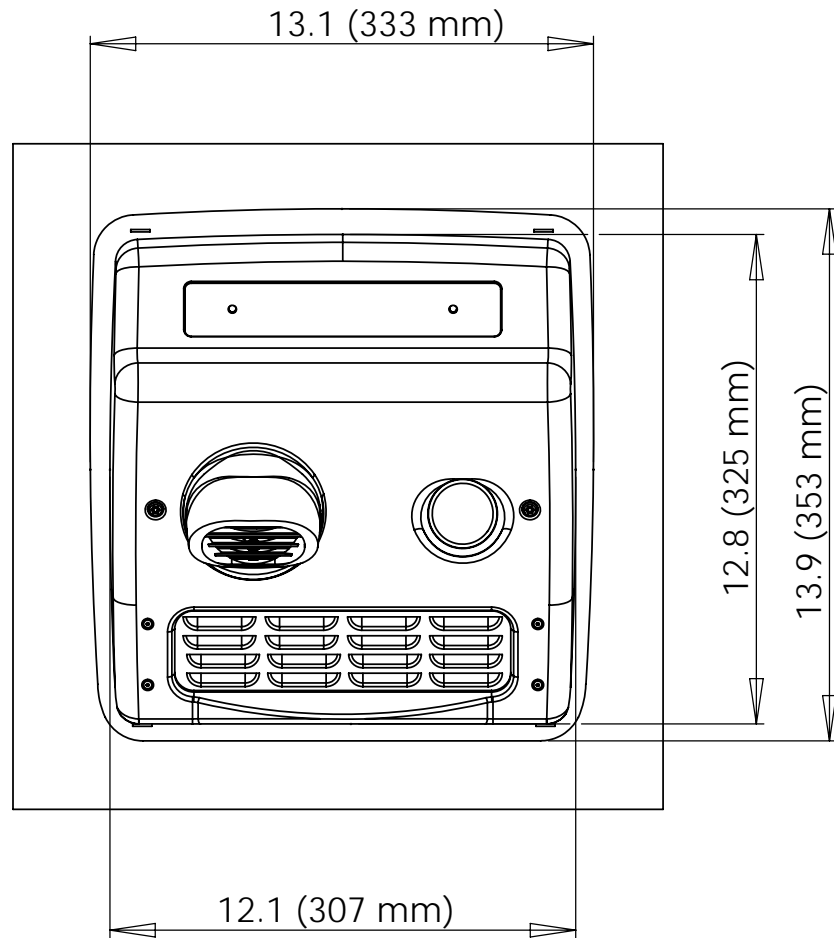
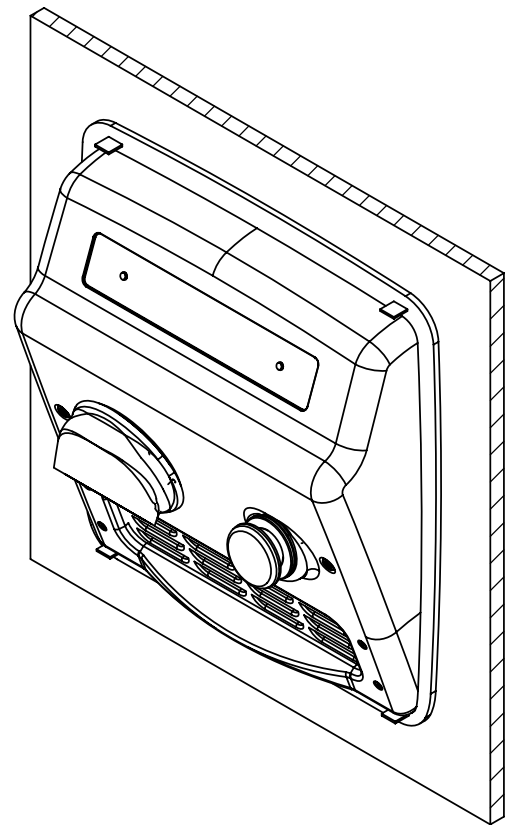

**PROPRIETARY AND CONFIDENTIAL**  
 THE INFORMATION CONTAINED IN THIS DRAWING IS THE SOLE PROPERTY OF <INSERT COMPANY NAME HERE>. ANY REPRODUCTION IN PART OR AS A WHOLE WITHOUT THE WRITTEN PERMISSION OF <INSERT COMPANY NAME HERE> IS PROHIBITED.

		UNLESS OTHERWISE SPECIFIED:		NAME	DATE			
		DIMENSIONS ARE IN INCHES	DRAWN	V.H.	12/20/07	TITLE:  Model XRA5		
		TOLERANCES:	CHECKED	D.S.	12/20/07			
		FRACTIONAL ±	ENG APPR.					
		ANGULAR: MACH ± BEND ±	MFG APPR.					
		TWO PLACE DECIMAL ±	Q.A.			SIZE	DWG. NO.	REV
		THREE PLACE DECIMAL ±	COMMENTS:			<b>B</b>		<b>B</b>
		INTERPRET GEOMETRIC TOLERANCING PER:				SCALE:1:5	WEIGHT:	SHEET 1 OF 1
		MATERIAL						
NEXT ASSY	USED ON	FINISH						
		DO NOT SCALE DRAWING						

8 7 6 5 4 3 2 1