

# Regal® 137 XL Flushometer



► **Models Available**

- Regal 137 XL

► **Description**

Exposed Water Closet Flushometer, for back inlet squat toilets.

► **Flush Cycle**

- Model 137-1.6 Low Consumption (1.6 gpf/6.0 Lpf)

► **Specifications**

Quiet, Exposed, Diaphragm Type, Chrome Plated Closet Flushometer with the following features:

- ADA Compliant Metal Oscillating Non-Hold-Open Handle
- 1" I.P.S. Screwdriver Bak-Chek™ Angle Stop
- Control Stop Plug
- Sweat Solder Adapter with Cover Tube
- Adjustable Tailpiece
- Cast Wall Flange with Set Screw
- Vacuum Breaker Flush Connection
- Spud Coupling and Spud Flange for 1½" Top Spud
- High Copper, Low Zinc Brass Castings for Dezincification Resistance
- Non-Hold-Open Handle and No External Volume Adjustment to Ensure Water Conservation
- Low Consumption flush accuracy controlled by Para-Flo™ Technology
- Handle Packing, Stop Seat and Vacuum Breaker to be Molded from PERMEX™ Rubber Compound for Chloramine Resistance

Valve Body, Cover, Tailpiece and Control Stop shall be in conformance with ASTM Alloy Classification for Semi-Red Brass. Valve shall be in compliance to the applicable sections of ASSE 1037.

► **Accessories**

See Accessories Section of the Sloan catalog for available accessories.

► **Fixtures**

Consult Sloan for Sloan brand matching fixture options.

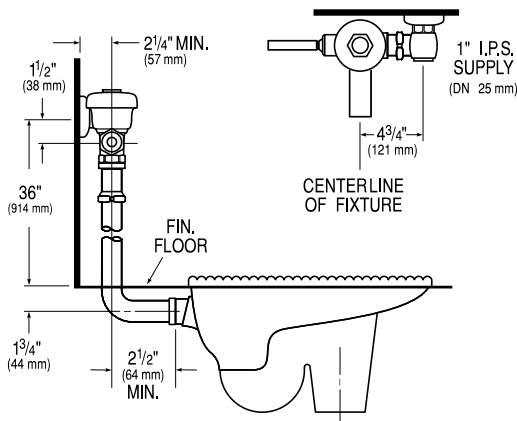

Listed by I.A.P.M.O.



This space for Architect/Engineer approval

The information contained in this document is subject to change without notice.



SLOAN VALVE COMPANY • 10500 SEYMOUR AVE. • FRANKLIN PARK, IL. 60131  
Ph: 1-800-9-VALVE-9 or 1-847-671-4300 • Fax: 1-800-447-8329 or 1-847-671-4380  
www.sloanvalve.com