

► **Description**

Battery Powered, Sensor Activated Sloan ECOS® Electronic Dual Flush Model Retrofit Conversion Kit for Exposed Closet Flushometers.

► **Flush Cycle**

Full Flush (Large Button – 1.6 gpf/6.0 Lpf), Reduced Flush (Small Button – 1.1 gpf/4.2 Lpf)

► **Specifications**

Quiet, Exposed, Sloan ECOS® Electronic Dual Flush, Battery Powered, Sensor Activated Closet Flushometer Retrofit Conversion Kit for Sloan **Royal®**, **Regal Pro®** and **Regal®** Flushometers with the following features:

- If the user is present for less than one minute and leaves the sensing zone or chooses the small override button, a reduced flush initiates (1.1 gpf/4.2 Lpf) eliminating liquid and paper waste, saving 1/2 gallon of water
- If the user is present for greater than one minute and leaves the zone or chooses the large override button, the full flush initiates (1.6 gpf/6.0 Lpf) eliminating solid waste and paper
- Reduces water volume by up to 30% when a reduced flush occurs
- PERMEX® Synthetic Rubber Flex Tube Diaphragm with twin linear filtered bypass and vortex cleansing action designed for improved life and reduced maintenance
- ADA Compliant Sloan ECOS® Electronic Dual Flush Battery Powered Infrared Sensor for automatic “No Hands” operation
- Infrared Sensor with Multiple-focused, Lobular Sensing Fields for high and low target detection with adjustment screw
- Latching Solenoid Operator
- Engineered Metal Cover with replaceable Lens Window
- User friendly three (3) second Flush Delay
- Courtesy Flush® Override Button
- Four (4) Size AA alkaline Batteries included: Duracell® with DURALOCK Power Preserve Technology™-guaranteed for up to 10 years in storage
- “Low Battery” Flashing LED
- Initial Set-up Range Indicator Light (first 10 minutes)
- Installation Tools provided
- Diaphragm molded from PERMEX® Rubber Compound for Chloramine resistance

► **Variations**

- Z** Locking Ring for Zurn® Flush Valve Bodies

► **Special Finishes**

- PB** Polished Brass (PVD Finish)
- BN** Brushed Nickel (PVD Finish)
- SF** Satin Chrome

► **Accessories**

See Accessories Section and Sloan ECOS® Accessories Section of the Sloan catalog for details on these and other Sloan ECOS® Electronic Dual Flush Flushometer variations.

► **Fixtures**

Consult Sloan for Sloan brand matching fixture options.



RESS-C shown installed on an existing Sloan Flushometer.

RESS-C units do *NOT* include a Valve Body, Supply Stop or Vacuum Breaker.



► **ADA Compliant**

► **Manual Operation**

Sloan ECOS® Electronic Dual Flush Flushometers incorporate intuitive Split-button design for easy manual activation. The small button controls the reduced flush cycle (1.1 gpf/4.2 Lpf), the large button controls the full flush cycle (1.6 gpf/6.0 Lpf). Straightforward graphics alert user to proper activation. Reduced flush for liquid waste, full flush for solid waste. To further educate the user, two (2) instructional wall plates are included with each Sloan ECOS® Flushometer.

► **Automatic Operation**

Sloan ECOS® Electronic Dual Flush Flushometers can also be activated via multi-lobular infrared sensor. By detecting user presence and duration, the Sloan ECOS® Smart Sense Technology™ will determine the proper flush volume for unequalled water efficiency.

► **Functional & Hygienic**

Touchless, sensor operation eliminates the need for user contact to help control the spread of infectious diseases. The Sloan ECOS® Electronic Dual Flush Flushometers are provided with *Reduced* or *Full* Flush Override Buttons to allow a “courtesy flush” for individual user comfort.

► **Warranty**

3 year (limited)

► **Patented**

D598,976

This space for Architect/Engineer approval	
Job Name _____	Date _____
Model Specified _____	Quantity _____
Variations Specified _____	
Customer/Wholesaler _____	
Contractor _____	
Architect _____	



Listed by I.A.P.M.O.



LISTED 376U



MODEL RESS-C-1.6/1.1 Electronic Dual Flush

- ▶ **Description**
Battery Powered, Sensor Activated Sloan ECOS® Electronic Dual Flush Model Retrofit Conversion Kit for Exposed Closet Flushometers.
- ▶ **Flush Cycle**
Full Flush (Large Button – 1.6 gpf/6.0 Lpf), Reduced Flush (Small Button – 1.1 gpf/4.2 Lpf)

Sloan ECOS® Electronic Dual Flush Flush Volume For RESS-C Retrofit Models

The Flush Volume of the Sloan ECOS® Electronic Dual Flush Valve is controlled by the Flex Tube Diaphragm Kit.

Reference Chart

Fixture & Flush	Regulator Color
1.6 gpf (6.0 Lpf) Closet	Green
1.28 gpf (4.8 Lpf) Closet	Green

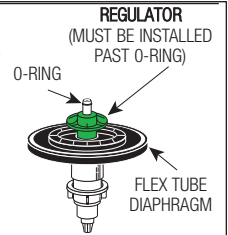

RESS-C Sloan ECOS® Electronic Dual Flush Valves are supplied with it's lowest flush volume configuration.

When installing a new Regulator on a Flex Tube Diaphragm Kit, be sure to push the Regulator past the O-ring when installing.

Note: Never use more water than needed. Low Consumption water closets and urinals will not function properly on excess water.

ELECTRICAL SPECIFICATIONS

- ▶ **Control Circuit**
Solid State
6 VDC Input
8 Second Arming Delay
3 Second Flush Delay
- ▶ **Sloan ECOS® Dual Flush Sensor Type**
Active Infrared
- ▶ **Sloan ECOS® Dual Flush Sensor Range**
Nominal 22" - 42" (559 mm - 1067 mm),
Adjustable ± 8" (203 mm)
- ▶ **Battery Type**
(4) Size AA Alkaline; Duracell® with DURALOCK Power Preserve Technology™
- ▶ **Battery Life**
Three (3) Years @ 4,000 Flushes/Month
- ▶ **Indicator Lights**
Range Adjustment/Low Battery
- ▶ **Operating Pressure**
15 - 100 psi (104 - 689 kPa)
- ▶ **Sentinel Flush**
Once Every 72 Hours After the Last Flush

1. A continuous, invisible light beam is emitted from the Sloan ECOS® Dual Flush Sensor.

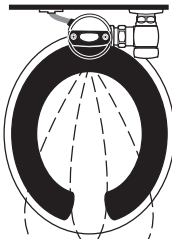

2. As the user enters the beam's effective range, 22" - 42" (559 mm to 1067 mm), the beam is reflected into the Scanner Window to activate the Output Circuit. Once activated, the Output Circuit continues in a "hold" mode for as long as the user remains within the effective range of the sensor. If the user stays longer than 65 seconds, a full flush will automatically initiate when the user leaves.

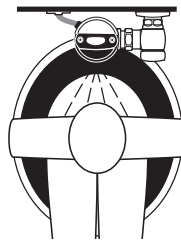

3. Once a user is detected, if the user leaves in 65 seconds or less, a reduced flush will automatically initiate. The circuit automatically resets and is ready for the next user.

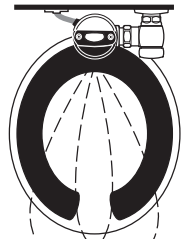

VALVE ROUGH-IN

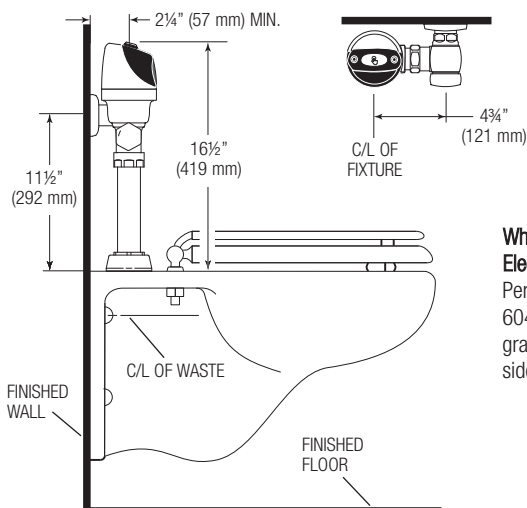

When installing the Sloan ECOS® Electronic Dual Flush in a handicap stall:
Per the ADA Guidelines (section 604.9.4) it is recommended that the grab bars be split or shifted to the wide side of the stall.

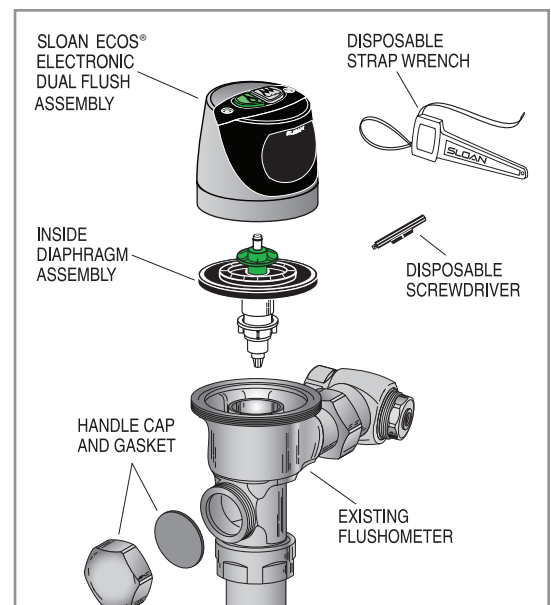

SLOAN VALVE COMPANY • 10500 SEYMOUR AVENUE • FRANKLIN PARK, IL 60131

Phone: 1-800-9-VALVE-9 or 1-847-671-4300 • Fax: 1-800-447-8329 or 1-847-671-4380 • www.sloanvalve.com