

## FEATURES & BENEFITS

---

## OPTIONS

---

For more information, visit [www.hawesco.com](http://www.hawesco.com) or call (888) 640-4297.



## SPECIFICATIONS

---

The Haws VRKSHE.D is a valve repair kit for the TWBS.SHE mixing valve. This kit includes parts to repair the hot shut off.

## APPLICATIONS

---

## KIT INSTALLATION INSTRUCTIONS

### **VRKSHE.A: KIT, REPAIR, TWBS.SHE, COMPLETE**

CONSISTS OF VRKSHE.B, VRKSHE.C, AND VRKSHE.D. FOLLOW INSTRUCTIONS OUTLINED FOR EACH AS NOTED ON THIS SHEET.

### **VRKSHE.B: KIT, REPAIR, TWBS.SHE, MAIN MIXING CHAMBER (REFER TO SHEET 2)**

1. REMOVE 4 COVER BOLTS AND 4 WASHERS AS SHOWN (NOTE 9/16" HEX).
2. REMOVE COVER.
3. REMOVE O-RING FROM COVER AND REPLACE WITH NEW O-RING FROM KIT.
4. REMOVE OVERLOAD ASSEMBLY FROM COVER BY PULLING STRAIGHT OUT, AND REPLACE WITH NEW OVERLOAD ASSEMBLY FROM KIT.
5. REMOVE PISTON/THERMOSTAT ASSEMBLY FROM VALVE BY PULLING STRAIGHT UP ON PISTON.
6. REMOVE CYLINDER ASSEMBLY FROM VALVE BY PULLING FIRMLY STRAIGHT UP ON THE CYLINDER ASSEMBLY.
7. REMOVE THREE PISTON SPRINGS FROM VALVE FUNNEL.
8. REMOVE VALVE FUNNEL FROM VALVE BY PULLING STRAIGHT UP ON FUNNEL AND FUNNEL O-RING IF IT DOES NOT COME OUT WITH THE FUNNEL.
9. INSTALL NEW FUNNEL O-RING AND FUNNEL FROM KIT.
10. INSTALL NEW CYLINDER ASSEMBLY FROM KIT AS SHOWN ON SHEET 2 BY PRESSING FIRMLY STRAIGHT DOWN AND ROCKING THE ASSEMBLY TO WORK IT PAST THE COLD INLET CHANNEL.
11. INSTALL 3 NEW PISTON SPRINGS FROM KIT INTO VALVE FUNNEL.
12. INSTALL NEW PISTON ASSEMBLY INTO CYLINDER AS SHOWN ON SHEET 2, BEING CAREFUL TO CLOCK THE PISTON SUCH THAT THE THREE FLATS UNDER THE PISTON SIT ON THE PISTON SPRINGS. THE PISTON SHOULD MOVE FREELY AGAINST THE SPRING PRESSURE IN THE CYLINDER.
13. INSTALL THE EXISTING COVER ON THE VALVE (CLOCKING IS NOT CRITICAL) AND RE-INSTALL THE FOUR WASHERS AND COVER BOLTS.
14. TIGHTEN BOLTS IN A CROSS PATTERN EVENLY UNTIL THE COVER CONTACTS THE VALVE BODY.
15. TORQUE BOLTS TO 25 FT-LBS.

### **VRKSHE.C: KIT, REPAIR, TWBS.SHE, CHECK STOPS (REFER TO SHEET 4)**

1. NOTE: HOT AND COLD CHECK STOP ASSEMBLIES ARE IDENTICAL.
2. REMOVE HOT CHECK STOP COVER WITH ADJUSTABLE WRENCH (3/4" FLATS).
3. REMOVE SPRING, CHECK STOP ASSEMBLY, CAGE, AND MESH SCREEN FROM VALVE.
4. CLEAN ANY VISIBLE DEBRIS FROM CHECK STOP CAVITY.
5. INSTALL NEW MESH SCREEN, CAGE, AND CHECK STOP ASSEMBLY FROM KIT AS SHOWN ON SHEET 3.
6. INSTALL NEW SPRING, ADJUSTMENT SCREW, AND CHECK STOP COVER FROM KIT. ADJUSTMENT SCREW SHOULD ALWAYS BE FULLY OUT (CCW) UNLESS THERE IS A NEED TO SHUT OFF THE HOT OR COLD WATER FOR TESTING.
7. REPEAT STEPS 2-6 WITH COLD CHECK STOP ASSEMBLY.

### **VRKSHE.D: KIT, REPAIR, TWBS.SHE, HOT SHUT OFF (REFER TO SHEET 4)**

1. REMOVE HOT SHUT OFF COVER WITH 1-3/8" WRENCH OR ADJUSTABLE WRENCH.
2. REMOVE SPRING, SEAT ASSEMBLY, OVERLOAD ASSEMBLY, AND CYLINDER/THERMOSTAT ASSEMBLY FROM CAVITY BY PULLING STRAIGHT OUT. COMPONENTS CAN ALSO BE PUSHED OUT WITH A FINGER INSERTED INTO THE TEPID WATER OUTLET PORT OF THE VALVE BODY.
3. INSTALL NEW CYLINDER/THERMOSTAT ASSEMBLY, OVERLOAD ASSEMBLY, SEAT ASSEMBLY, AND SPRING FROM KIT AS SHOWN ON SHEET 4.
4. INSTALL NEW HOT SHUT OFF COVER FROM KIT AS SHOWN ON SHEET 4.

### **VRKSHE.E: KIT, BASIC MAINT, TWBS.SHE, T-STATS+O-RINGS**

1. REFER TO EXPLODED VIEWS IN SHEETS 2 - 4 AND DISASSEMBLY AND RE-ASSEMBLY INSTRUCTIONS ON THIS PAGE.
2. RECOMMEND ANY DRY O-RINGS BE LUBRICATED WITH FOOD GRADE SILICONE LUBRICANT, SUCH AS DOW CORNING 111 PRIOR TO INSTALLATION.
3. THERMOSTATS SHOULD BE INSTALLED SNUGLY, TAKING CARE NOT TO DAMAGE THEM.
4. MAIN COVER CAP SCREWS SHOULD BE TORQUED TO 25 FT-LBS PER VRKSHE.B INSTRUCTIONS.

**WARNING! VALVES MUST ALWAYS BE SAFELY REMOVED FROM SERVICE AND DRAINED PRIOR TO PERFORMING MAINTENANCE OR REPAIRS!**

		1455 KLEPPE LANE SPARKS, NEVADA 89431 (775) 359-4712 FAX (775) 359-7424 E-MAIL: HAWS@HAWS.CO.COM WEBSITE: WWW.HAWS.CO.COM	
		MODEL(S) VRKSHE.A, VRKSHE.B, VRKSHE.C, VRKSHE.D, AND VRKSHE.E	PART NUMBER 0510000958 REVISION 1
ECN NO. 5431 DRAWN: DP APPROVED: DP	REVISED PER: ECN: 5431 DATE: 08/28/19 DATE: 08/29/19	BY: DP CHK'D: FV	SCALE: -- DRAWING TYPE: INSTALLATION SIZE: A SHEET 1 OF 4

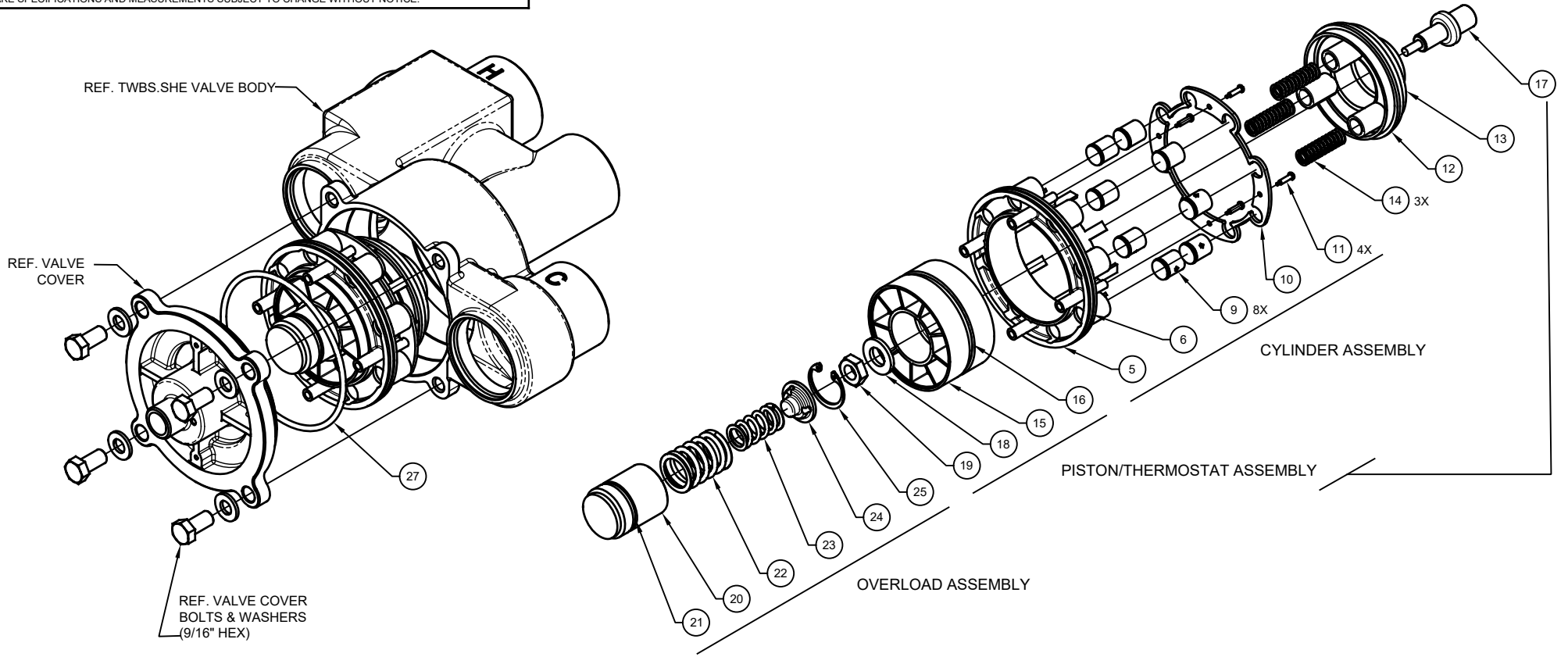

VRKSHE.B MAIN MIXING CHAMBER REPAIR KIT				
ITEM #	SUB ASSEMBLY	QTY	DESCRIPTION	VRKSHE.E BASIC MAINT. KIT
27	N/A	1	O-RING DASH# 242 (3.984 ID X .139 W)	INCLUDED
21	OVERLOAD ASSEMBLY	1	O-RING DASH# 123 (1.174 ID X .103 W)	INCLUDED
20	OVERLOAD ASSEMBLY	1	OVERLOAD HOUSING	
22	OVERLOAD ASSEMBLY	1	OVERLOAD COMPRESSION SPRING 1.095 OD	
23	OVERLOAD ASSEMBLY	1	OVERLOAD COMPRESSION SPRING 0.720 OD	
24	OVERLOAD ASSEMBLY	1	OVERLOAD INSERT	
25	OVERLOAD ASSEMBLY	1	RETAINING RING	
19	PISTON/THERMOSTAT ASSY	1	THERMOSTAT RETAINING NUT SST M12X1.75	
18	PISTON/THERMOSTAT ASSY	1	FLAT WASHER SST 12MM	
15	PISTON/THERMOSTAT ASSY	1	PLUNGER	
16	PISTON/THERMOSTAT ASSY	1	O-RING DASH# 231 (2.609 ID X .139 W)	INCLUDED
17	PISTON/THERMOSTAT ASSY	1	THERMOSTAT MAIN 60-100	INCLUDED
5	CYLINDER ASSEMBLY	1	SLEEVE	
6	CYLINDER ASSEMBLY	1	O-RING DASH# 231 (3.987 ID X .103 W)	INCLUDED
9	CYLINDER ASSEMBLY	8	CHECK VALVE 14MM	
10	CYLINDER ASSEMBLY	1	CHECK VALVE RETAINER	
11	CYLINDER ASSEMBLY	4	SCREW #4 SST	
14	N/A	3	PISTON SPRING SST	
12	N/A	1	FUNNEL, VALVE	
13	N/A	1	O-RING DASH# 335 (2.725 ID X .210 W)	INCLUDED

**VRKSHE.B MAIN MIXING CHAMBER REPAIR KIT SHOWN ON THIS SHEET**



**Haws**<sup>®</sup>

1455 KLEPPE LANE  
SPARKS, NEVADA 89431  
(775) 359-4712 FAX (775) 359-7424  
E-MAIL: HAWS@HAWSCO.COM  
WEBSITE: WWW.HAWSCO.COM

ECN NO. 5431	REVISED PER ECN: 5431	BY: DP	MODEL(S) VRKSHE.A, VRKSHE.B, VRKSHE.C, VRKSHE.D, AND VRKSHE.E	PART NUMBER 051000958
DRAWN: DP	DATE: 08/26/19	CHK'D: FV	REVISION 1	
APPROVED: DP	DATE: 08/29/19	SCALE: N/A	DRAWING TYPE: INSTALLATION	SHEET 2 OF 4

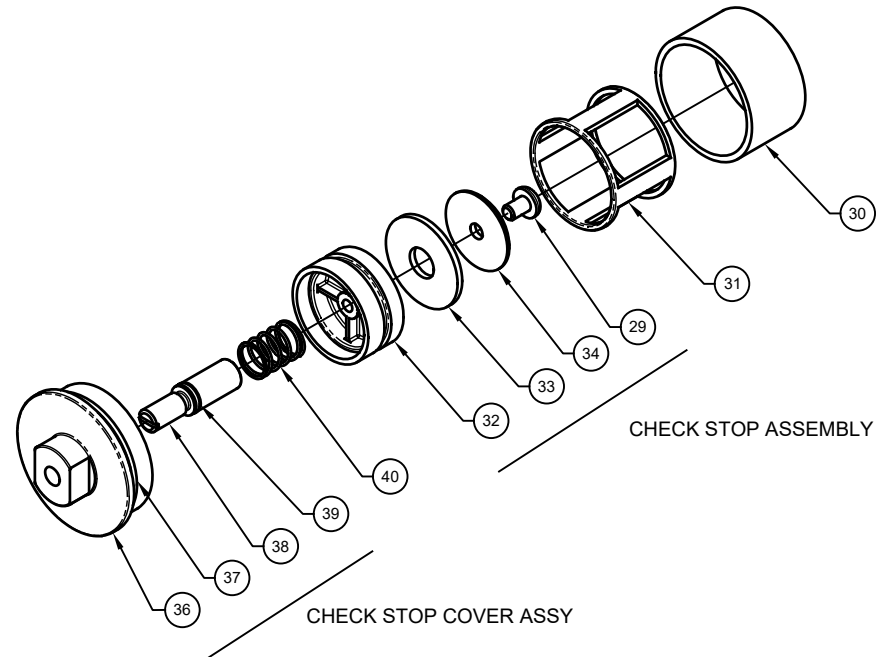
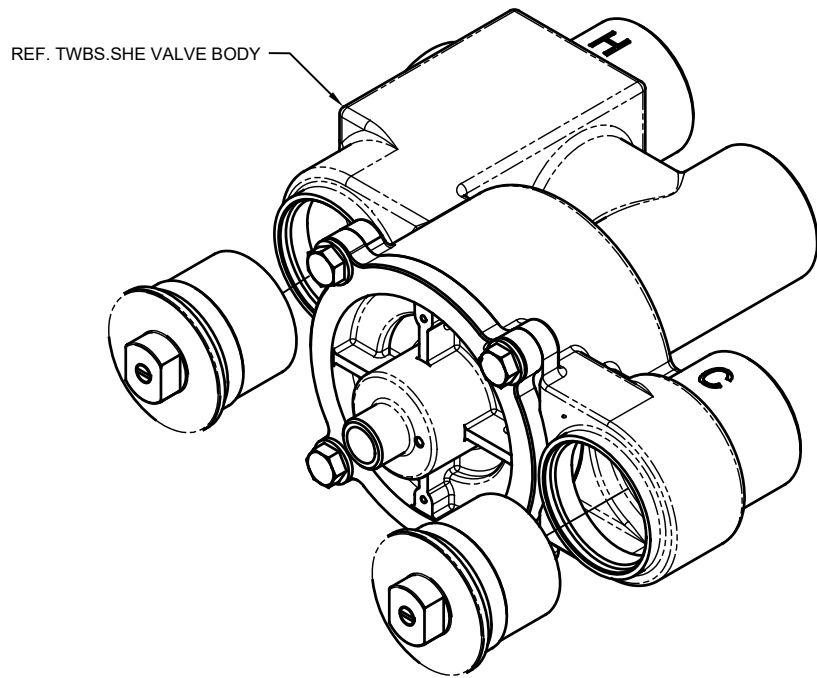

NOTE: HOT AND COLD CHECK STOPS ARE IDENTICAL. KIT INCLUDES BOTH.

**VRKSHE.C CHECK STOPS REPAIR KIT  
SHOWN ON THIS SHEET**

VRKSHE.C CHECK STOPS REPAIR KIT				
ITEM #	SUB ASSEMBLY	QTY	DESCRIPTION	VRKSHE.E BASIC MAINT. KIT
36	CHECK STOP COVER ASSY	2	CHECK STOP COVER BONNET	
37	CHECK STOP COVER ASSY	2	O-RING DASH# 225 (1.859 ID X .139 W)	INCLUDED
39	CHECK STOP COVER ASSY	2	O-RING DASH# 012 (.364 ID X .070 W)	INCLUDED
38	CHECK STOP COVER ASSY	2	STEM CHECK STOP ADJUST. SCREW	
40	N/A	2	SPRING	
32	CHECK STOP ASSY	2	POPPET (NO O-RING)	
33	CHECK STOP ASSY	2	WASHER EPDM	
34	CHECK STOP ASSY	2	WASHER CHECK STOP	
29	CHECK STOP ASSY	2	SCREW SST 1/4-20	
31	N/A	2	CAGE SLEEVE	
30	N/A	2	MESH SCREEN SST	

				1455 KLEPPE LANE SPARKS, NEVADA 89431 (775) 359-4712 FAX (775) 359-7424 E-MAIL: HAWS@HAWS.CO.COM WEBSITE: WWW.HAWS.CO.COM	
				ECN NO. 5431 DRAWN: DP APPROVED: DP	REVISED PER: ECN: 5431 DATE: 08/26/19 DATE: 08/29/19
SCALE: N/A		DRAWING TYPE: INSTALLATION		SIZE: A SHEET 3 OF 4	

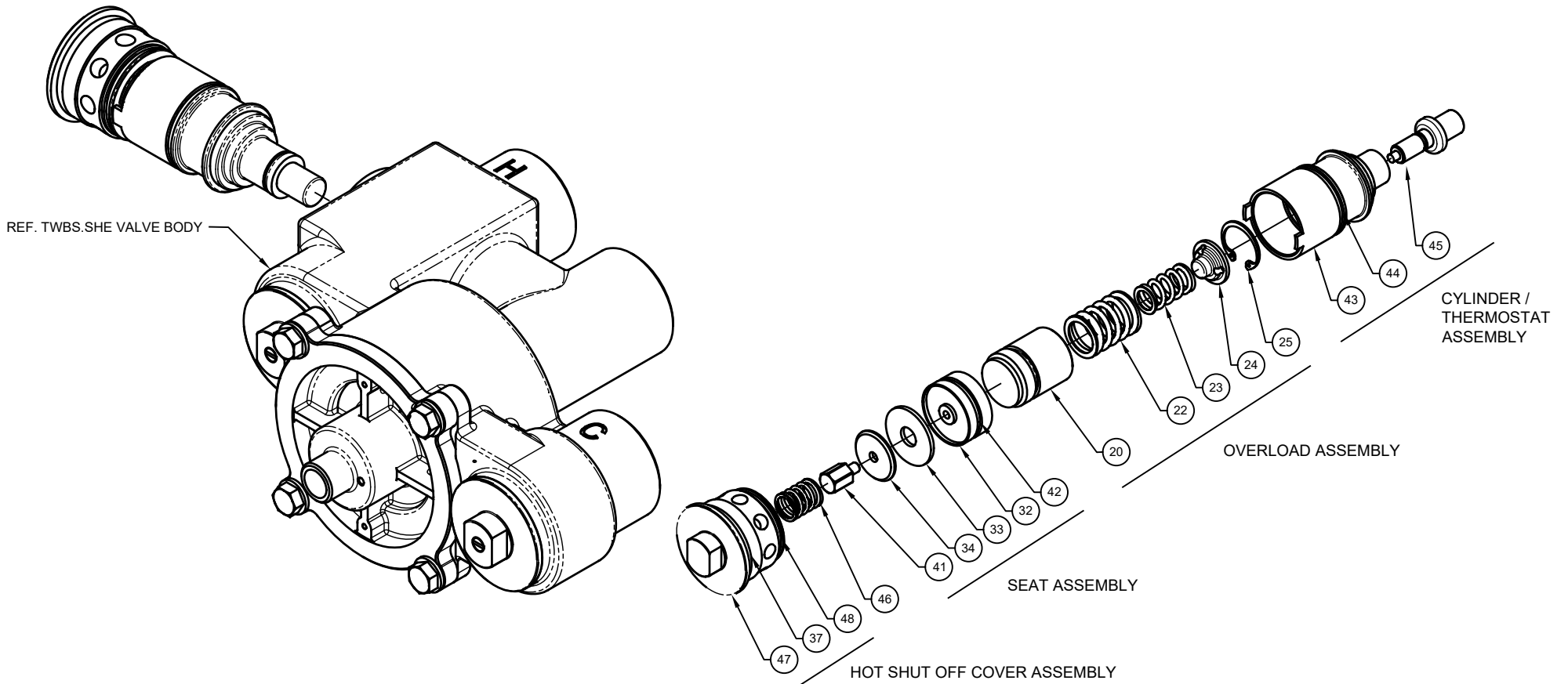

VRKSHE.D HOT SHUT OFF REPAIR KIT				
ITEM #	SUB ASSEMBLY	QTY	DESCRIPTION	VRKSHE.E BASIC MAINT. KIT
47	HOT SHUT OFF COVER ASSEMBLY	1	HOT SHUT OFF COVER BONNET	
37	HOT SHUT OFF COVER ASSEMBLY	1	O-RING DASH# 225 (1.859 ID X .139 W)	INCLUDED
48	HOT SHUT OFF COVER ASSEMBLY	1	O-RING DASH# 131 (1.674 ID X .103 W)	INCLUDED
46	N/A	1	SPRING SST	
41	SEAT ASSEMBLY	1	SPRING GUIDE	
34	SEAT ASSEMBLY	1	WASHER	
33	SEAT ASSEMBLY	1	WASHER EPDM	
32	SEAT ASSEMBLY	1	POPPET	
42	SEAT ASSEMBLY	1	O-RING DASH# 018 (.739 ID X .070 W)	INCLUDED
20	OVERLOAD ASSEMBLY	1	OVERLOAD HOUSING	
22	OVERLOAD ASSEMBLY	1	OVERLOAD COMPRESSION SPRING 1.095 OD	
23	OVERLOAD ASSEMBLY	1	OVERLOAD COMPRESSION SPRING .720 OD	
24	OVERLOAD ASSEMBLY	1	INSERT	
25	OVERLOAD ASSEMBLY	1	RETAINING RING	
43	CYLINDER/THERMOSTAT ASSY	1	CYLINDER HOUSING	
44	CYLINDER/THERMOSTAT ASSY	1	O-RING DASH# 130 (1.612 ID X .103 W)	INCLUDED
45	CYLINDER/THERMOSTAT ASSY	1	THERMOSTAT 90-95	INCLUDED

**VRKSHE.D HOT SHUT OFF REPAIR KIT SHOWN ON THIS SHEET**



UNDER HOUSING

# Haws®

1455 KLEPPE LANE  
SPARKS, NEVADA 89431  
(775) 359-4712 FAX (775) 359-7424  
E-MAIL: HAWS@HAWSCO.COM  
WEBSITE: WWW.HAWSCO.COM

ECN NO. 5431	REVISED PER BY: ECN: 5431 DP	MODEL(S)	PART NUMBER
DRAWN: DP	DATE: 08/26/19	CHK'D: FV	VRKSHE.A, VRKSHE.B, VRKSHE.C, VRKSHE.D AND VRKSHE.E
APPROVED: DP	DATE: 08/29/19	SCALE: N/A	DRAWING TYPE: INSTALLATION
			REVISION 1
			SIZE: A SHEET 4 OF 4