

FEATURES & BENEFITS

OPTIONS

For more information, visit www.hawesco.com or call (888) 640-4297.



SPECIFICATIONS

The Haws VRKHF.F is a valve repair kit for the TWBS.HF mixing valve. This kit includes parts to repair the cold water bypass.

APPLICATIONS

KIT INSTALLATION INSTRUCTIONS

VRKHF.A: KIT, REPAIR, TWBS.HF, COMPLETE

CONSISTS OF VRKHF.B, VRKHF.C, VRKHF.D, AND VRKHF.F. FOLLOW INSTRUCTIONS OUTLINED FOR EACH AS NOTED ON THE FIRST TWO SHEETS.

VRKHF.B: KIT, REPAIR, TWBS.HF, MAIN MIXING CHAMBER (REFER TO SHEET 3)

1. REMOVE 4 COVER AND 4 WASHERS AS SHOWN (NOTE 9/16" HEX).
2. REMOVE COVER.
3. REMOVE O-RING FROM COVER AND REPLACE WITH NEW O-RING FROM KIT.
4. REMOVE OVERLOAD ASSEMBLY FROM COVER BY PULLING STRAIGHT OUT, AND REPLACE WITH NEW OVERLOAD ASSEMBLY FROM KIT.
5. REMOVE PISTON/THERMOSTAT ASSEMBLY FROM VALVE BY PULLING STRAIGHT UP ON PISTON.
6. REMOVE CYLINDER ASSEMBLY FROM VALVE BY PULLING FIRMLY STRAIGHT UP ON THE CYLINDER ASSEMBLY.
7. REMOVE THREE PISTON SPRINGS FROM VALVE FUNNEL.
8. REMOVE VALVE FUNNEL FROM VALVE BY PULLING STRAIGHT UP ON FUNNEL AND FUNNEL O-RING IF IT DOES NOT COME OUT WITH THE FUNNEL.
9. INSTALL NEW FUNNEL O-RING AND FUNNEL FROM KIT.
10. INSTALL NEW CYLINDER ASSEMBLY FROM KIT AS SHOWN ON SHEET 3 BY PRESSING FIRMLY STRAIGHT DOWN AND ROCKING THE ASSEMBLY TO WORK IT PAST THE COLD INLET CHANNEL.
11. INSTALL 3 NEW PISTON SPRINGS FROM KIT INTO VALVE FUNNEL.
12. INSTALL NEW PISTON ASSEMBLY INTO CYLINDER AS SHOWN ON SHEET 3, BEING CAREFUL TO CLOCK THE PISTON SUCH THAT THE THREE FLATS UNDER THE PISTON SIT ON THE PISTON SPRINGS. THE PISTON SHOULD MOVE FREELY AGAINST THE SPRING PRESSURE IN THE CYLINDER.
13. INSTALL THE EXISTING COVER ON THE VALVE (CLOCKING IS NOT CRITICAL) AND RE-INSTALL THE FOUR WASHERS AND COVER BOLTS.
14. TIGHTEN BOLTS IN A CROSS PATTERN EVENLY UNTIL THE COVER CONTACTS THE VALVE BODY.
15. TORQUE BOLTS TO 25 FT-LBS.

VRKHF.C: KIT, REPAIR, TWBS.HF, CHECK STOPS (REFER TO SHEET 4)

1. NOTE: HOT AND COLD CHECK STOP ASSEMBLIES ARE IDENTICAL.
2. REMOVE HOT CHECK STOP COVER WITH ADJUSTABLE WRENCH (3/4" FLATS).
3. REMOVE SPRING, CHECK STOP ASSEMBLY, CAGE, AND MESH SCREEN FROM VALVE.
4. CLEAN ANY VISIBLE DEBRIS FROM CHECK STOP CAVITY.
5. INSTALL NEW MESH SCREEN, CAGE, AND CHECK STOP ASSEMBLY FROM KIT AS SHOWN ON SHEET 4.
6. INSTALL NEW SPRING, ADJUSTMENT SCREW, AND CHECK STOP COVER FROM KIT. ADJUSTMENT SCREW SHOULD ALWAYS BE FULLY OUT (CCW) UNLESS THERE IS A NEED TO SHUT OFF THE HOT OR COLD WATER FOR TESTING.
7. REPEAT STEPS 2-6 WITH COLD CHECK STOP ASSEMBLY.

VRKHF.D: KIT, REPAIR, TWBS.HF, HOT SHUT OFF (REFER TO SHEET 5)

1. REMOVE HOT SHUT OFF COVER WITH 1-3/8" WRENCH OR ADJUSTABLE WRENCH.
2. REMOVE SPRING, SEAT ASSEMBLY, OVERLOAD ASSEMBLY, AND CYLINDER/THERMOSTAT ASSEMBLY FROM CAVITY BY PULLING STRAIGHT OUT. COMPONENTS CAN ALSO BE PUSHED OUT WITH A FINGER INSERTED INTO THE TEPID WATER OUTLET PORT OF THE VALVE BODY.
3. INSTALL NEW CYLINDER/THERMOSTAT ASSEMBLY, OVERLOAD ASSEMBLY, SEAT ASSEMBLY, AND SPRING FROM KIT AS SHOWN ON SHEET 5.
4. INSTALL NEW HOT SHUT OFF COVER FROM KIT AS SHOWN ON SHEET 5.

WARNING! VALVES MUST ALWAYS BE SAFELY REMOVED FROM SERVICE AND DRAINED PRIOR TO PERFORMING MAINTENANCE OR REPAIRS!

		1455 KLEPPE LANE SPARKS, NEVADA 89431 (775) 359-4712 FAX (775) 359-7424 E-MAIL: HAWS@HAWS.CO.COM WEBSITE: WWW.HAWS.CO.COM	
		MODEL(S) VRKHF.A, VRKHF.B, VRKHF.C, VRKHF.D, VRKHF.E, AND VRKHF.F	PART NUMBER 0510000957 REVISION 1
ECN NO. 5430 DRAWN: DP APPROVED: DP	REVISED PER ECN: 5430 DATE: 08/20/19 DATE: 08/21/19	BY: DP CHK'D.: FV	SCALE: -- DRAWING TYPE: INSTALLATION SIZE: A SHEET 1 OF 6

KIT INSTALLATION INSTRUCTIONS

VRKHF.E: KIT, BASIC MAINT, TWBS.HF, T-STATS+O-RINGS

1. REFER TO EXPLODED VIEWS IN SHEETS 3 - 5 AND DISASSEMBLY AND RE-ASSEMBLY INSTRUCTIONS ON SHEETS 1-2. SEE ALSO DIAGRAMS AT RIGHT.
2. RECOMMEND ANY DRY O-RINGS BE LUBRICATED WITH FOOD GRADE SILICONE LUBRICANT, SUCH AS DOW CORNING 111 PRIOR TO INSTALLATION.
3. THERMOSTATS AND RETAINING NUT (18MM HEX) SHOULD BE INSTALLED ONLY SNUGLY, TAKING CARE NOT TO DAMAGE THERMOSTAT OR PISTON. STANDARD RIGHT HAND THREAD.
4. VALVE COVER BOLTS SHOULD BE TORQUED TO 25 FT-LBS PER VRKHF.B INSTRUCTIONS.

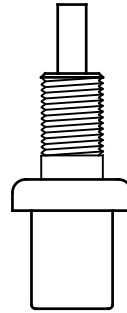

MAIN T-STAT
ITEM #17

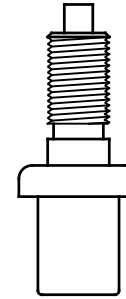

HOT SHUT OFF T-STAT
ITEM #45

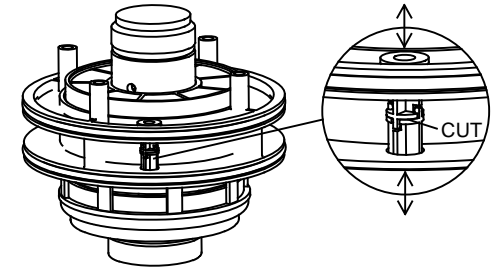

TO REPLACE O-RINGS ON DIVERTER, CUT EXISTING DIVERTER AT POINT NOTED WITH A PAIR OF DIAGONAL PLIERS TO REMOVE. CONFIRM NEW DIVERTER HALVES FROM KIT HAVE O-RINGS IN PLACE. INSTALL NEW DIVERTER HALFS FROM KIT FROM TOP AND BOTTOM AND SNAP TOGETHER IN MIDDLE AS SHOWN.

VRKHF.F: KIT REPAIR, TWBS.HF, COLD BYPASS (REFER TO SHEET 6)

NOTE: REPAIRS TO THE TWBS.HF COLD BYPASS SYSTEM ARE MODERATELY DIFFICULT. READ THROUGH THE FOLLOWING INSTRUCTIONS AND CONSIDER CONFIRMING THAT THE REPAIR IS NECESSARY BEFORE BEGINNING. REPAIR OF THE COLD BYPASS IS NOT INDICATED IF BOTH OF THE FOLLOWING TWO FIELD TESTS ARE PASSED:

A. DURING NORMAL OPERATION, WITH THE TEMPERATURE ADJUSTMENT CAP SCREW FULLY LOOSENED COUNTERCLOCKWISE, THE OUTLET WATER TEMPERATURE SHOULD REMAIN ABOVE 80°F (INDICATES COLD BYPASS SYSTEM IS NOT LEAKING EXCESSIVELY). RESTORE DESIRED WATER OUTLET TEMPERATURE BY TURNING TEMPERATURE ADJUSTMENT SCREW IN CLOCKWISE TO REDUCE TEMPERATURE FROM MAXIMUM OF APPROXIMATELY 85°F.

B. DURING NORMAL OPERATION, TURN OFF THE HOT WATER SUPPLY TO THE MIXING VALVE, EITHER WITH A VALVE IN THE HOT WATER LINE, OR BY GENTLY TURNING THE HOT CHECK STOP ADJUSTMENT SCREW CLOCKWISE (NO MORE THAN FLUSH) UNTIL THE OUTLET TEMPERATURE DROPS APPROXIMATELY TO THE COLD INLET TEMPERATURE. ACTIVATE AN ATTACHED SHOWER AND CONFIRM THAT FULL COLD FLOW RATE IS AVAILABLE TO THE SHOWER (INDICATES COLD BYPASS SYSTEM IS OPENING APPROPRIATELY). RESTORE HOT WATER SUPPLY TO THE TWBS.HF VALVE AFTER TEST.

1. LOOSEN THE TWO FLARE NUTS (3/4" HEX) ON THE COLD BYPASS TUBE ASSEMBLY (ITEM #52) AND SLIDE THEM TO THE CENTER OF THE TUBE.
2. THE COLD BYPASS TUBE ASSEMBLY SITS BETWEEN TWO FLARE FITTING ELBOWS (ITEMS #51). CAREFULLY TURN THE FLARE FITTING ELBOW (1/2" FLATS), LOCATED IN THE COLD BYPASS COVER, A SMALL AMOUNT COUNTERCLOCKWISE (LOOSEN). CAREFULLY TURN THE FLARE FITTING ELBOW (1/2" FLATS) LOCATED IN THE BOSS ON THE MAIN VALVE BODY CLOCKWISE (TIGHTEN). REPEAT THESE TWO SMALL ADJUSTMENTS UNTIL THE COLD BYPASS TUBE ASSEMBLY CAN BE REMOVED. NOTE THE POSITIONS OF THE TWO FLARE FITTING ELBOWS AT THIS POINT. IT WILL BE NECESSARY TO INSTALL THE NEW FLARE FITTING ELBOWS TO APPROXIMATELY THE SAME CLOCKING IN ORDER TO INSTALL THE NEW COLD BYPASS TUBE ASSEMBLY.
3. UNTHREAD AND REMOVE THE COLD BYPASS COVER (ITEM #50) BY TURNING COUNTERCLOCKWISE (3/4" FLATS).
4. IF THEY DO NOT COME OUT WITH THE COVER, REMOVE THE SPRING AND BYPASS VALVE ASSEMBLY BY LIFTING STRAIGHT OUT.
5. INSTALL A NEW BYPASS VALVE ASSEMBLY, SPRING, AND COLD BYPASS COVER FROM THE KIT. THE SPRING SHOULD BE SEATED IN THE CAVITY ON THE INSIDE OF THE COVER. GENTLY SNUG THE COLD BYPASS COVER AFTER THE FLANGE ON IT CONTACTS THE MAIN VALVE BODY.
6. APPLY LOCTITE 243 FROM THE KIT TO THE THREADS OF ONE OF THE TWO NEW FLARE FITTING ELBOWS INCLUDED IN THE KIT AND INSTALL THE NEW ELBOW IN THE COLD BYPASS COVER. TAKE CARE THAT THE NPT FITTING IS TIGHT ENOUGH TO SEAL AND CLOCKED SUCH AS TO ALLOW THE BYPASS TUBE ASSEMBLY TO BE WORKED INTO PLACE IN STEP 8.
7. UNTHREAD AND REMOVE THE OLD FLARE FITTING ELBOW FROM THE BOSS ON THE MAIN VALVE BODY. APPLY LOCTITE 243 TO THE THREADS OF THE SECOND NEW FLARE FITTING ELBOW IN THE KIT AND INSTALL THE NEW ELBOW IN THE MAIN VALVE BOSS. TAKE CARE THAT THE NPT FITTING IS TIGHT ENOUGH TO SEAL AND CLOCKED SUCH AS TO ALLOW THE BYPASS TUBE ASSEMBLY TO BE WORKED INTO PLACE BETWEEN THE TWO FLARE ELBOWS.
8. HOLD THE NEW BYPASS TUBE ASSEMBLY FROM THE KIT IN PLACE AND CAREFULLY TIGHTEN THE FLARE FITTING ELBOW IN THE COLD BYPASS COVER AND LOOSEN THE FLARE FITTING ELBOW IN THE MAIN VALVE BOSS A LITTLE BIT AT A TIME UNTIL THE TWO ELBOWS DIRECTLY FACE EACH OTHER AND THE TUBE RUNS STRAIGHT BETWEEN THEM.
9. THREAD THE FLARE NUTS ON THE COLD BYPASS TUBE ASSEMBLY ONTO THE FLARE ELBOWS FINGER TIGHT, THEN TURN AN ADDITIONAL QUARTER TURN WITH A 3/4" HEX WRENCH.



Haws®

1455 KLEPPE LANE
SPARKS, NEVADA 89431
(775) 359-4712 FAX (775) 359-7424
E-MAIL: HAWS@HAWSO.COM
WEBSITE: WWW.HAWSO.COM

ECN NO. 5430	REVISED PER ECN: 5430	BY: DP	MODEL(S)	PART NUMBER
DRAWN: DP	DATE: 08/20/19	CHKD.: FV	VRKHF.A, VRKHF.B, VRKHF.C, VRKHF.D, VRKHF.E, AND VRKHF.F	0510000957
APPROVED: DP	DATE: 08/21/19	SCALE: --	DRAWING TYPE: INSTALLATION	REVISION 1
			SIZE: A	SHEET 2 OF 6

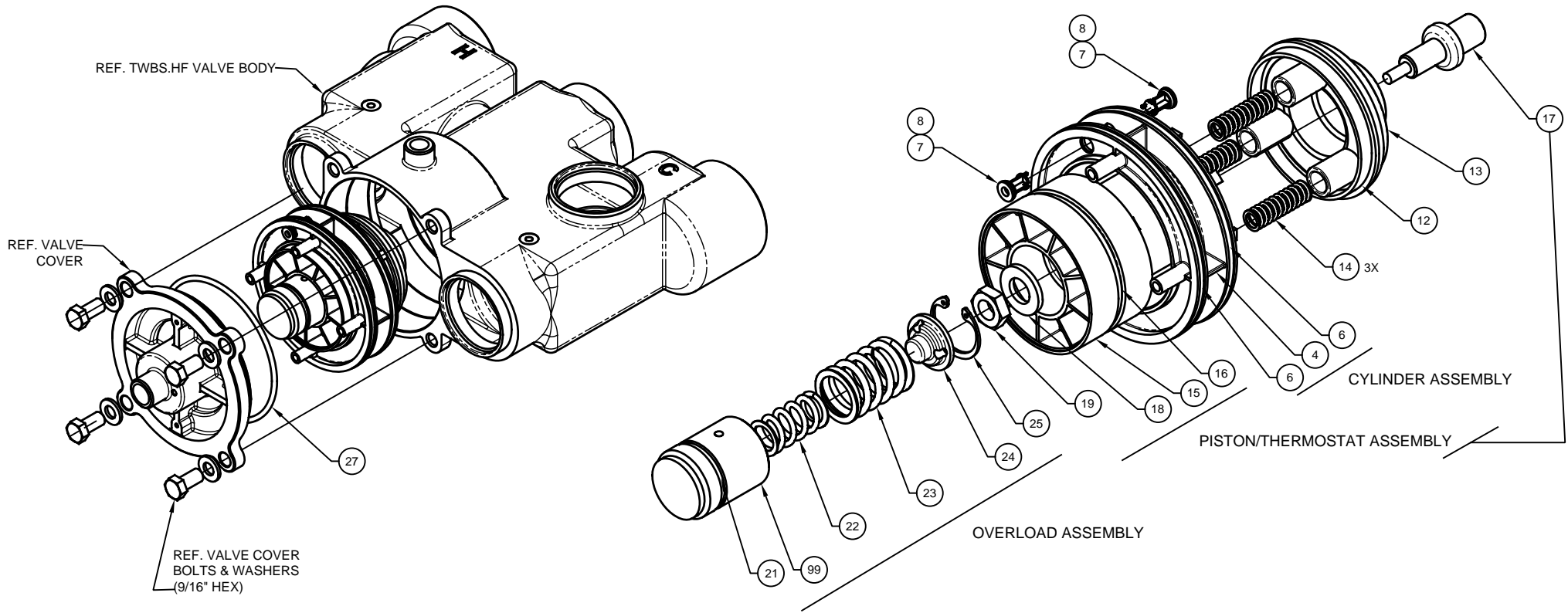

VRKHF.B MAIN MIXING CHAMBER REPAIR KIT

ITEM #	SUB ASSEMBLY	QTY	DESCRIPTION	VRK02E.E BASIC MAINT. KIT
27	N/A	1	O-RING DASH# 242 (3.984 ID X .139 W)	INCLUDED
21	OVERLOAD ASSEMBLY	1	O-RING DASH# 123 (1.174 ID X .103 W)	INCLUDED
99	OVERLOAD ASSEMBLY	1	OVERLOAD HOUSING	
22	OVERLOAD ASSEMBLY	1	OVERLOAD COMPRESSION SPRING 1.095 OD	
23	OVERLOAD ASSEMBLY	1	OVERLOAD COMPRESSION SPRING 0.720 OD	
24	OVERLOAD ASSEMBLY	1	OVERLOAD INSERT	
25	OVERLOAD ASSEMBLY	1	RETAINING RING	
19	PISTON/THERMOSTAT ASSY	1	THERMOSTAT RETAINING NUT SST M12X1.75	
18	PISTON/THERMOSTAT ASSY	1	FLAT WASHER SST 12MM	
15	PISTON/THERMOSTAT ASSY	1	PLUNGER	
16	PISTON/THERMOSTAT ASSY	1	O-RING DASH# 231 (2.609 ID X .139 W)	INCLUDED
17	PISTON/THERMOSTAT ASSY	1	THERMOSTAT MAIN 60-100	INCLUDED
4	CYLINDER ASSEMBLY	1	SLEEVE	
6	CYLINDER ASSEMBLY	2	O-RING DASH# 231 (3.987 ID X .103 W)	INCLUDED
7	CYLINDER ASSEMBLY	2	DIVERTER HI-CAP VLV EXT B-P	
8	CYLINDER ASSEMBLY	2	O-RING DASH# 010 (.239 ID X .070 W)	INCLUDED
14	N/A	3	PISTON SPRING SST	
12	N/A	1	FUNNEL, VALVE	
13	N/A	1	O-RING DASH# 335 (2.725 ID X .210 W)	INCLUDED

VRKHF.B MAIN MIXING CHAMBER REPAIR KIT SHOWN ON THIS SHEET



Haws[®]

1455 KLEPPE LANE
SPARKS, NEVADA 89431
(775) 359-4712 FAX (775) 359-7424
E-MAIL: HAWS@HAWS.CO.COM
WEBSITE: WWW.HAWS.CO.COM

ECN NO. 5430		REVISED PER ECN: 5430		BY: DP		MODEL(S)		PART NUMBER	
DRAWN: DP		DATE: 08/20/19		CHKD.: FV		VRKHF.A, VRKHF.B, VRKHF.C, VRKHF.D, VRKHF.E, AND VRKHF.F		0510000957	
APPROVED: DP		DATE: 08/21/19		SCALE: N/A		DRAWING TYPE: INSTALLATION		REVISION 1	
								SHEET 3 OF 6	

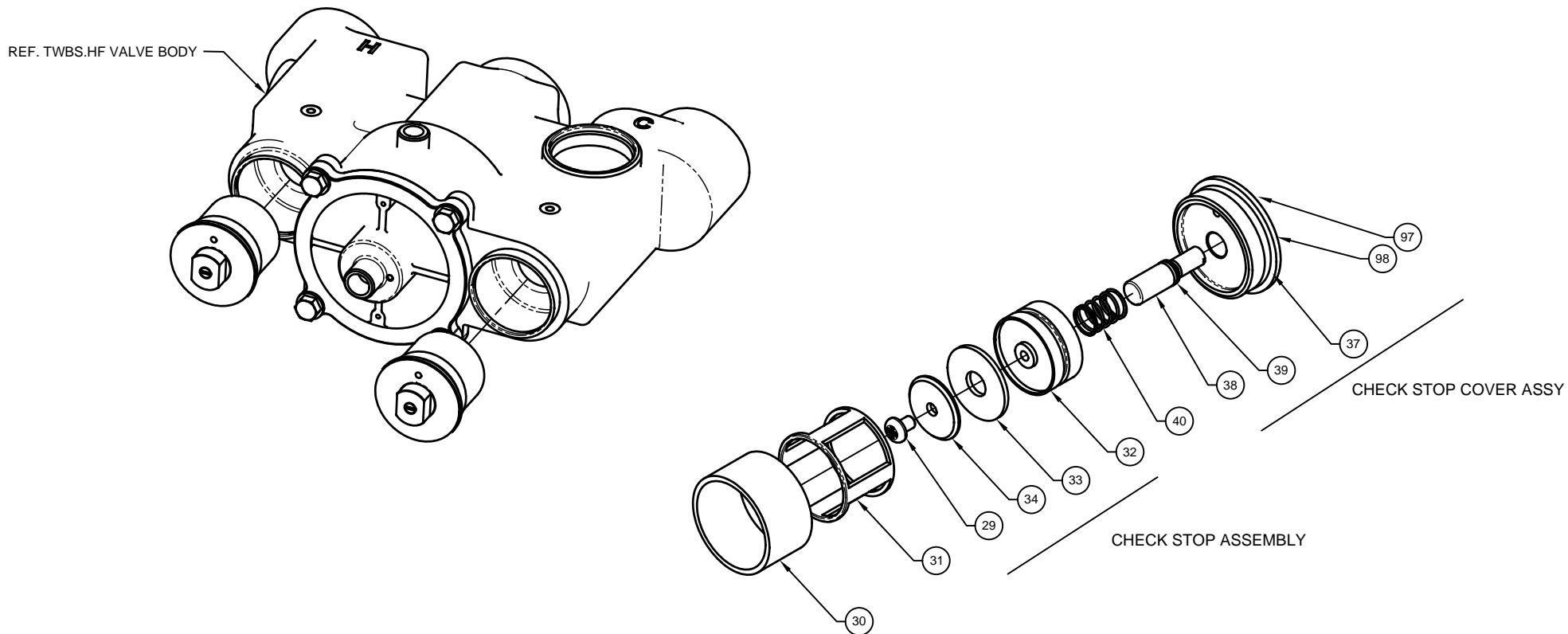

NOTE: HOT AND COLD CHECK STOPS ARE IDENTICAL. KIT INCLUDES BOTH.

VRKHF.C CHECK STOPS REPAIR KIT

ITEM #	SUB ASSEMBLY	QTY	DESCRIPTION	VRKHF.E BASIC MAINT. KIT
97	CHECK STOP COVER ASSY	2	DRAIN PLUG PLUG SCREW	
98	CHECK STOP COVER ASSY	2	CHECK STOP COVER BONNET	
37	CHECK STOP COVER ASSY	2	O-RING DASH# 225 (1.859 ID X .139 W)	INCLUDED
39	CHECK STOP COVER ASSY	2	O-RING DASH# 012 (.364 ID X .070 W)	INCLUDED
38	CHECK STOP COVER ASSY	2	STEM CHECK STOP ADJUST. SCREW	
40	N/A	2	SPRING	
32	CHECK STOP ASSY	2	POPPET (NO O-RING)	
33	CHECK STOP ASSY	2	WASHER EPDM	
34	CHECK STOP ASSY	2	WASHER CHECK STOP	
29	CHECK STOP ASSY	2	SCREW SST 1/4-20	
31	N/A	2	CAGE SLEEVE	
30	N/A	2	MESH SCREEN SST	

**VRKHF.C CHECK STOPS REPAIR KIT
SHOWN ON THIS SHEET**

		Haws [®]		1455 KLEPPE LANE SPARKS, NEVADA 89431 (775) 359-4712 FAX (775) 359-7424 E-MAIL: HAWS@HAWSO.COM WEBSITE: WWW.HAWSO.COM	
				ECN NO: 5430 DRAWN: DP APPROVED: DP	REVISED PER: ECN: 5430 DATE: 08/20/19 DATE: 08/21/19
SCALE: N/A		DRAWING TYPE: INSTALLATION		SIZE: A SHEET 4 OF 6	

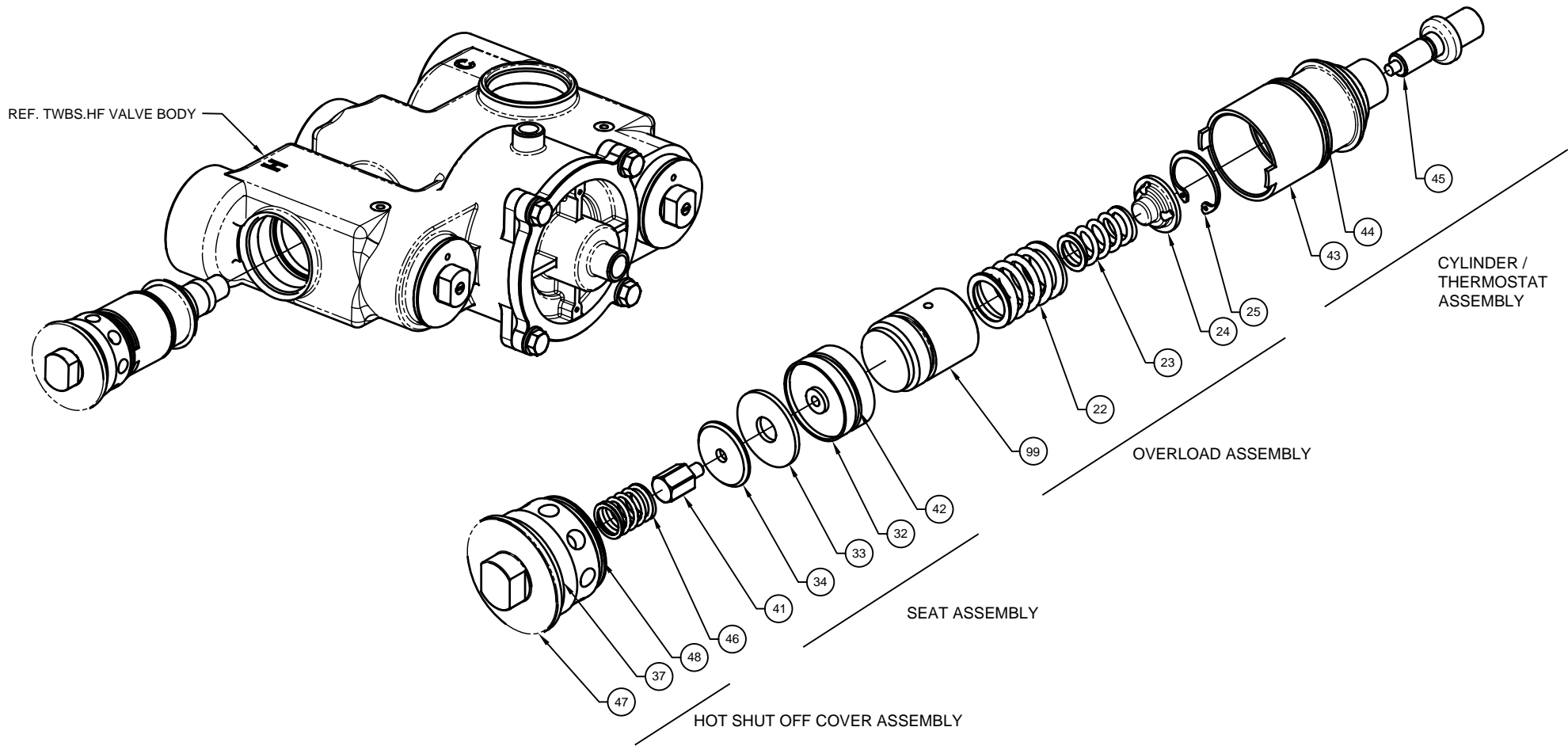

VRKHF.D HOT SHUT OFF REPAIR KIT

ITEM #	SUB ASSEMBLY	QTY	DESCRIPTION	VRK01H.E BASIC MAINT. KIT
47	HOT SHUT OFF COVER ASSEMBLY	1	HOT SHUT OFF COVER BONNET	
37	HOT SHUT OFF COVER ASSEMBLY	1	O-RING DASH# 225 (1.859 ID X .139 W)	INCLUDED
48	HOT SHUT OFF COVER ASSEMBLY	1	O-RING DASH# 131 (1.674 ID X .103 W)	INCLUDED
46	N/A	1	SPRING SST	
41	SEAT ASSEMBLY	1	SPRING GUIDE	
34	SEAT ASSEMBLY	1	WASHER	
33	SEAT ASSEMBLY	1	WASHER EPDM	
32	SEAT ASSEMBLY	1	POPPET	
42	SEAT ASSEMBLY	1	O-RING DASH# 018 (.739 ID X .070 W)	INCLUDED
99	OVERLOAD ASSEMBLY	1	OVERLOAD HOUSING	
22	OVERLOAD ASSEMBLY	1	OVERLOAD COMPRESSION SPRING 1.095 OD	
23	OVERLOAD ASSEMBLY	1	OVERLOAD COMPRESSION SPRING .720 OD	
24	OVERLOAD ASSEMBLY	1	INSERT	
25	OVERLOAD ASSEMBLY	1	RETAINING RING	
43	CYLINDER/THERMOSTAT ASSY	1	CYLINDER HOUSING	
44	CYLINDER/THERMOSTAT ASSY	1	O-RING DASH# 130 (1.612 ID X .103 W)	INCLUDED
45	CYLINDER/THERMOSTAT ASSY	1	THERMOSTAT 90-95	INCLUDED

VRKHF.D HOT SHUT OFF REPAIR KIT SHOWN ON THIS SHEET



DER HOUSING

Haws®

1455 KLEPPE LANE
SPARKS, NEVADA 89431
(775) 359-4712 FAX (775) 359-7424
E-MAIL: HAWS@HAWSCO.COM
WEBSITE: WWW.HAWSCO.COM

ECN NO. 5430		REVISED PER ECN: 5430		BY: DP		MODEL(S)		PART NUMBER	
DRAWN: DP		DATE: 08/20/19		CHKD.: FV		VRKHF.A, VRKHF.B, VRKHF.C, VRKHF.D VRKHF.E, AND VRKHF.F		0510000957	
APPROVED: DP		DATE: 08/21/19		SCALE: N/A		DRAWING TYPE: INSTALLATION		REVISION 1	
								SIZE: A SHEET 5 OF 6	

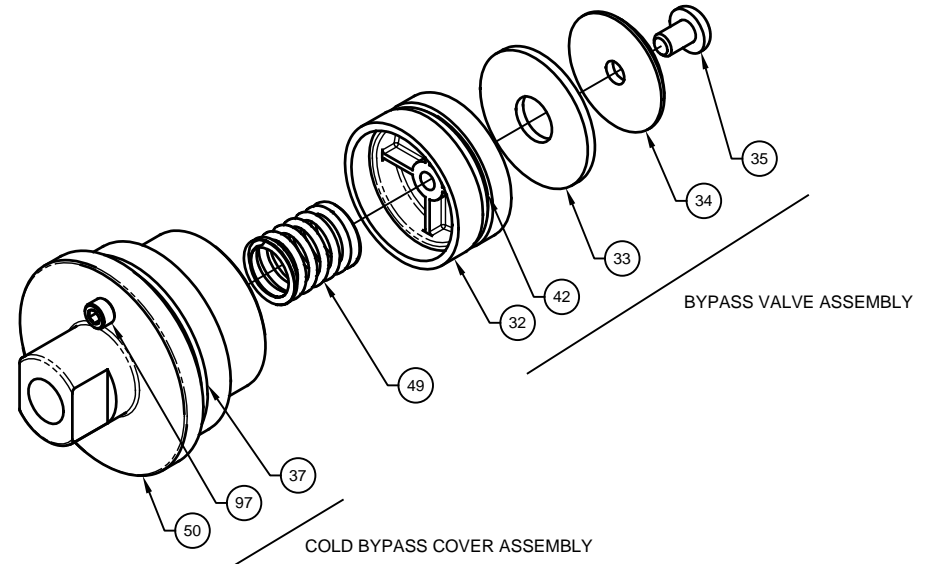
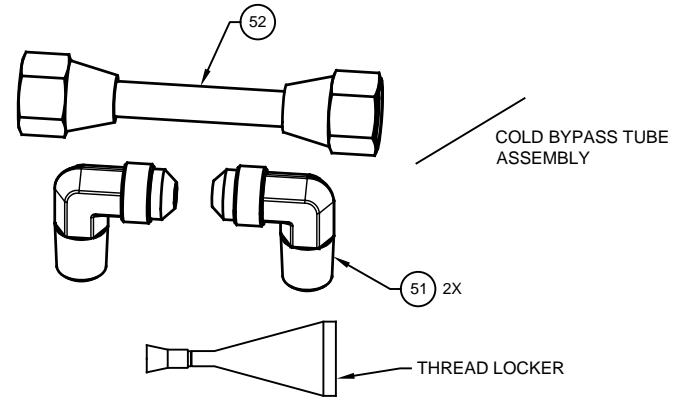
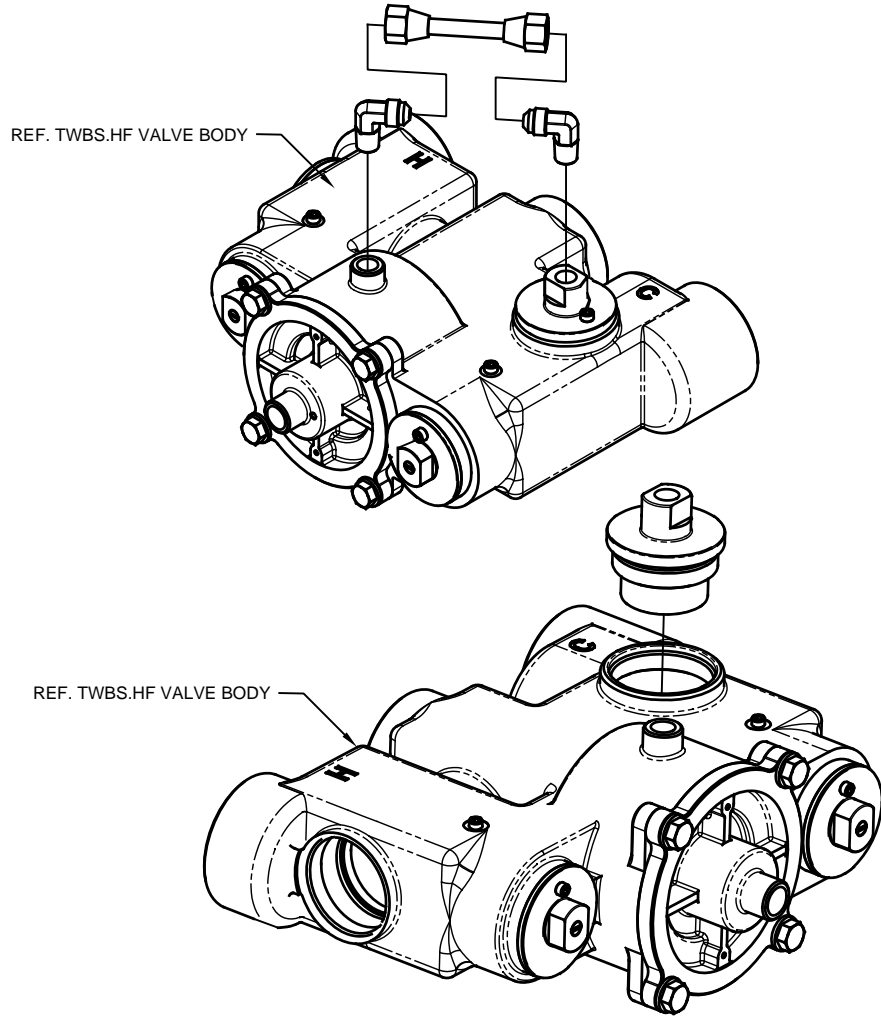

**VRKHF.F COLD BYPASS REPAIR KIT
SHOWN ON THIS SHEET**

VRKHF.F COLD BYPASS REPAIR KIT				
ITEM #	SUB ASSEMBLY	QTY	DESCRIPTION	VRKHF.E BASIC MAINT. KIT
50	COLD BYPASS COVER ASSY	1	COLD BYPASS COVER	
97	COLD BYPASS COVER ASSY	1	DRAIN PLUG PLUG SCREW	
37	COLD BYPASS COVER ASSY	1	O-RING DASH# 225 (1.859 ID X .139 W)	INCLUDED
49	N/A	1	SPRING	
32	BYPASS VALVE ASSEMBLY	1	POPPET	
42	BYPASS VALVE ASSEMBLY	1	O-RING DASH# 126 (1.362 ID X .103 W)	INCLUDED
33	BYPASS VALVE ASSEMBLY	1	WASHER EPDM	
34	BYPASS VALVE ASSEMBLY	1	WASHER CHECK STOP	
35	BYPASS VALVE ASSEMBLY	1	SCREW SST 1/4-20	
51	N/A	2	FLARE FITTING ELBOW	
52	COLD BYPASS TUBE ASSY	1	COLD BYPASS TUBE ASSEMBLY	
N/A	N/A	1	LOCTITE 243 THREAD LOCKER	INCLUDED



Haws[®]

1455 KLEPPE LANE
SPARKS, NEVADA 89431
(775) 359-4712 FAX (775) 359-7424
E-MAIL: HAWS@HAWSCO.COM
WEBSITE: WWW.HAWSCO.COM

ECN NO. 5430		REVISED PER ECN: 5430		BY: DP		MODEL(S)		PART NUMBER	
DRAWN: DP		DATE: 08/20/19		CHKD.: FV		VRKHF.A, VRKHF.B, VRKHF.C, VRKHF.D, VRKHF.E, AND VRKHF.F		0510000957	
APPROVED: DP		DATE: 08/21/19		SCALE: N/A		DRAWING TYPE: INSTALLATION		REVISION 1	
								SHEET 6 OF 6	