



model VRK01EFE.C

Mixing Valve Repair Kit

FEATURES & BENEFITS

OPTIONS

For more information, visit www.hawsc.com or call (888) 640-4297.



SPECIFICATIONS

The Haws VRK01EFE.C is a valve repair kit for the 9201EFE mixing valve. This kit includes parts to repair the check stops.

APPLICATIONS

KIT INSTALLATION INSTRUCTIONS

VRK01EFE.A: KIT, REPAIR, 9201EFE, COMPLETE

CONSISTS OF VRK01EFE.B AND VRK01EFE.C. FOLLOW INSTRUCTIONS OUTLINED FOR EACH AS NOTED ON THIS PAGE.

VRK01EFE.B: KIT, REPAIR, 9201EFE, MAIN MIXING CHAMBER (REFER TO SHEET 2)

1. REMOVE 4 COVER CAP SCREWS AS SHOWN.
2. REMOVE COVER.
3. REMOVE O-RING FROM COVER AND REPLACE WITH NEW O-RING FROM KIT.
4. REMOVE OVERLOAD ASSEMBLY FROM COVER BY PULLING STRAIGHT OUT, AND REPLACE WITH NEW OVERLOAD ASSEMBLY FROM KIT.
5. REMOVE PISTON/THERMOSTAT ASSEMBLY FROM VALVE BY PULLING STRAIGHT UP ON PISTON.
6. REMOVE CYLINDER ASSEMBLY FROM VALVE BY PULLING FIRMLY STRAIGHT UP ON THE CYLINDER ASSEMBLY.
7. REMOVE THREE PISTON SPRINGS FROM VALVE FUNNEL.
8. REMOVE VALVE FUNNEL FROM VALVE BY PULLING STRAIGHT UP ON FUNNEL AND FUNNEL O-RING IF IT DOES NOT COME OUT WITH THE FUNNEL.
9. INSTALL NEW FUNNEL O-RING AND FUNNEL FROM KIT.
10. INSTALL NEW CYLINDER ASSEMBLY FROM KIT AS SHOWN ON SHEET 2 BY PRESSING FIRMLY STRAIGHT DOWN AND ROCKING THE ASSEMBLY TO WORK IT PAST THE COLD INLET CHANNEL.
11. INSTALL 3 NEW PISTON SPRINGS FROM KIT INTO VALVE FUNNEL.
12. INSTALL NEW PISTON ASSEMBLY INTO CYLINDER AS SHOWN ON SHEET 2, BEING CAREFUL TO CLOCK THE PISTON SUCH THAT THE THREE FLATS UNDER THE PISTON SIT ON THE PISTON SPRINGS. THE PISTON SHOULD MOVE FREELY AGAINST THE SPRING PRESSURE IN THE CYLINDER.
13. INSTALL THE EXISTING COVER ON THE VALVE (CLOCKING IS NOT CRITICAL) AND INSERT THE FOUR COVER CAP SCREWS.
14. TIGHTEN SCREWS IN A CROSS PATTERN EVENLY UNTIL THE COVER CONTACTS THE VALVE BODY.
15. TORQUE COVER CAP SCREWS TO 62 IN-LBS.

VRK01EFE.C: KIT, REPAIR, 9201EFE, CHECK STOPS (REFER TO SHEET 3)

1. NOTE: HOT AND COLD CHECK STOP ASSEMBLIES ARE IDENTICAL.
2. REMOVE HOT CHECK STOP COVER WITH 1-3/8" WRENCH OR ADJUSTABLE WRENCH.
3. REMOVE SPRING, CHECK STOP ASSEMBLY, CAGE, AND MESH SCREEN FROM VALVE.
4. CLEAN ANY VISIBLE DEBRIS FROM CHECK STOP CAVITY.
5. INSTALL NEW MESH SCREEN, CAGE, AND CHECK STOP ASSEMBLY FROM KIT AS SHOWN ON SHEET 3.
6. INSTALL NEW SPRING, ADJUSTMENT SCREW, AND CHECK STOP COVER FROM KIT. ADJUSTMENT SCREW SHOULD ALWAYS BE FULLY OUT (CCW) UNLESS THERE IS A NEED TO SHUT OFF THE HOT OR COLD WATER FOR TESTING.
7. REPEAT STEPS 2-6 WITH COLD CHECK STOP ASSEMBLY.

VRK01EFE.E: KIT, BASIC MAINT, 9201EFE, T-STATS+O-RINGS

1. REFER TO EXPLODED VIEWS IN SHEETS 2-3 AND DISASSEMBLY AND RE-ASSEMBLY INSTRUCTIONS ON THIS PAGE.
2. RECOMMEND ANY DRY O-RINGS BE LUBRICATED WITH FOOD GRADE SILICONE LUBRICANT, SUCH AS DOW CORNING 111 PRIOR TO INSTALLATION.
3. THERMOSTATS SHOULD BE INSTALLED SNUGLY, TAKING CARE NOT TO DAMAGE THEM.
4. MAIN COVER CAP SCREWS SHOULD BE TORQUED TO 62 IN-LBS PER VRK01EFE.B INSTRUCTIONS.

		Haws [®]		1455 KLEPPE LANE SPARKS, NEVADA 89431 (775) 359-4712 FAX (775) 359-7424 E-MAIL: HAWS@HAWSCO.COM WEBSITE: WWW.HAWSCO.COM	
ECN NO. 5426	REVISED PER ECN: 5426	BY: DP	MODEL(S)		
DRAWN: DP	DATE: 05/13/19	CHK'D: FV	VRK01EFE.A/.B/.C/.E VALVE REPAIR KITS		PART NUMBER 0510000953
APPROVED: NE	DATE: 05/21/19	SCALE: 1:2.125	DRAWING TYPE: INSTALLATION	SIZE: A	SHEET 1 OF 3
					REVISION 1

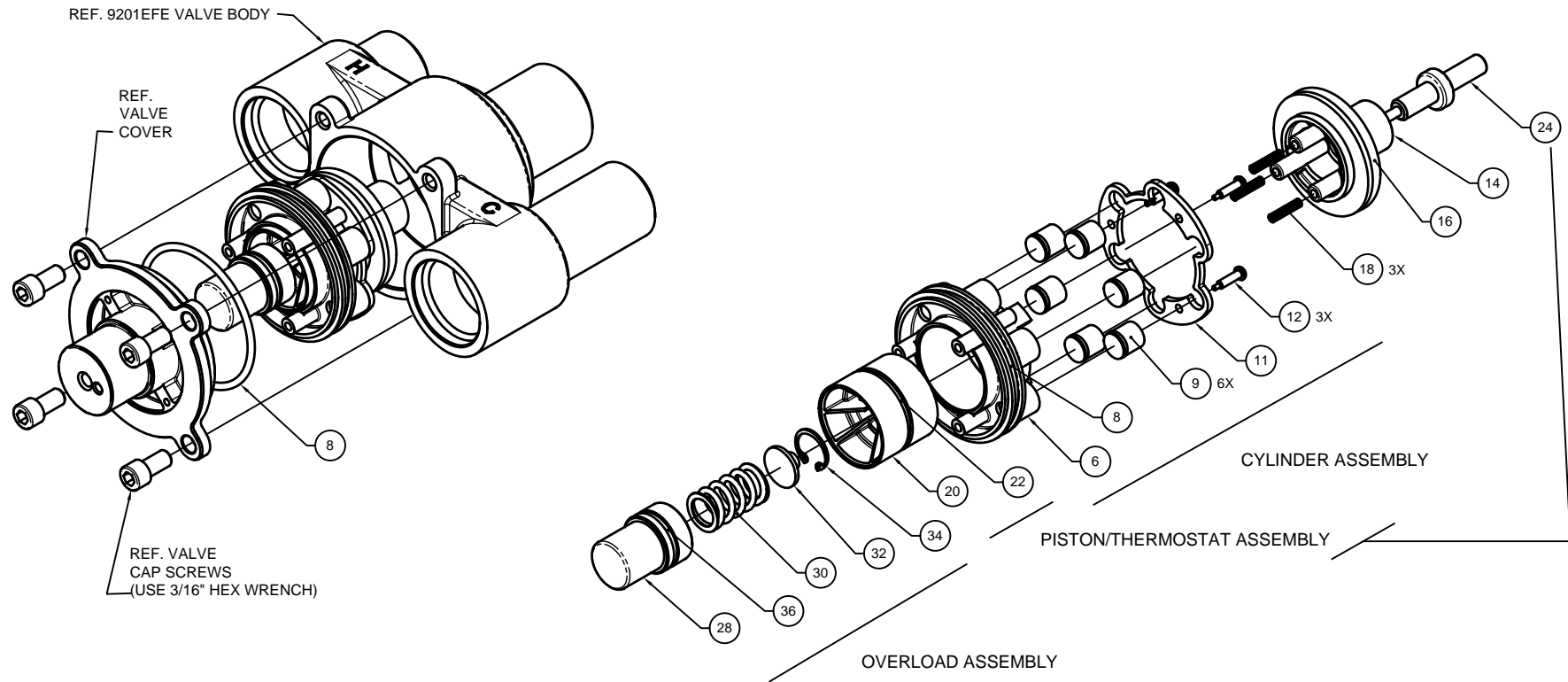

VRK01EFE.B MAIN MIXING CHAMBER REPAIR KIT				
ITEM #	SUB ASSEMBLY	QTY	DESCRIPTION	VRK01EFE.E BASIC MAINT. KIT
8	N/A	1	O-RING DASH# 137 (2.050 ID X .103 W)	INCLUDED
28	OVERLOAD ASSEMBLY	1	OVERLOAD HOUSING	
36	OVERLOAD ASSEMBLY	1	O-RING DASH# 018 (.739 ID X .070 W)	INCLUDED
30	OVERLOAD ASSEMBLY	1	OVERLOAD COMPRESSION SPRING	
32	OVERLOAD ASSEMBLY	1	OVERLOAD INSERT	
34	OVERLOAD ASSEMBLY	1	RETAINING RING	
20	PISTON/THERMOSTAT ASSY	1	PLUNGER	
22	PISTON/THERMOSTAT ASSY	1	O-RING DASH# 024 (1.114 ID X .070 W)	INCLUDED
24	PISTON/THERMOSTAT ASSY	1	THERMOSTAT MAIN 60-100	INCLUDED
6	CYLINDER ASSEMBLY	1	SLEEVE	
8	CYLINDER ASSEMBLY	1	O-RING DASH# 137 (2.050 ID X .103 W)	INCLUDED
9	CYLINDER ASSEMBLY	6	CHECK VALVE 10MM	
11	CYLINDER ASSEMBLY	1	CHECK VALVE RETAINER	
12	CYLINDER ASSEMBLY	4	SCREW #4 SST	
18	N/A	3	PISTON SPRING SST	
14	N/A	1	FUNNEL, VALVE	
16	N/A	1	O-RING DASH# 325 (1.475 ID X .210 W)	INCLUDED

**VRK01EFE.B MAIN MIXING CHAMBER REPAIR KIT
SHOWN ON THIS SHEET**

		Haws [®]		1455 KLEPPE LANE SPARKS, NEVADA 89431 (775) 359-4712 FAX (775) 359-7424 E-MAIL: HAWS@HAWSCO.COM WEBSITE: WWW.HAWSCO.COM	
				MODEL(S)	VRK01EFE.A/B/C/E VALVE REPAIR KITS
ECN NO. 5426	REVISED PER ECN: 5426	BY: DP	DATE: 05/13/19	CHKD.: FV	REVISION 1
APPROVED: NE	DATE: 05/21/19	SCALE: N/A	DRAWING TYPE: INSTALLATION	SIZE: A	SHEET 2 OF 3

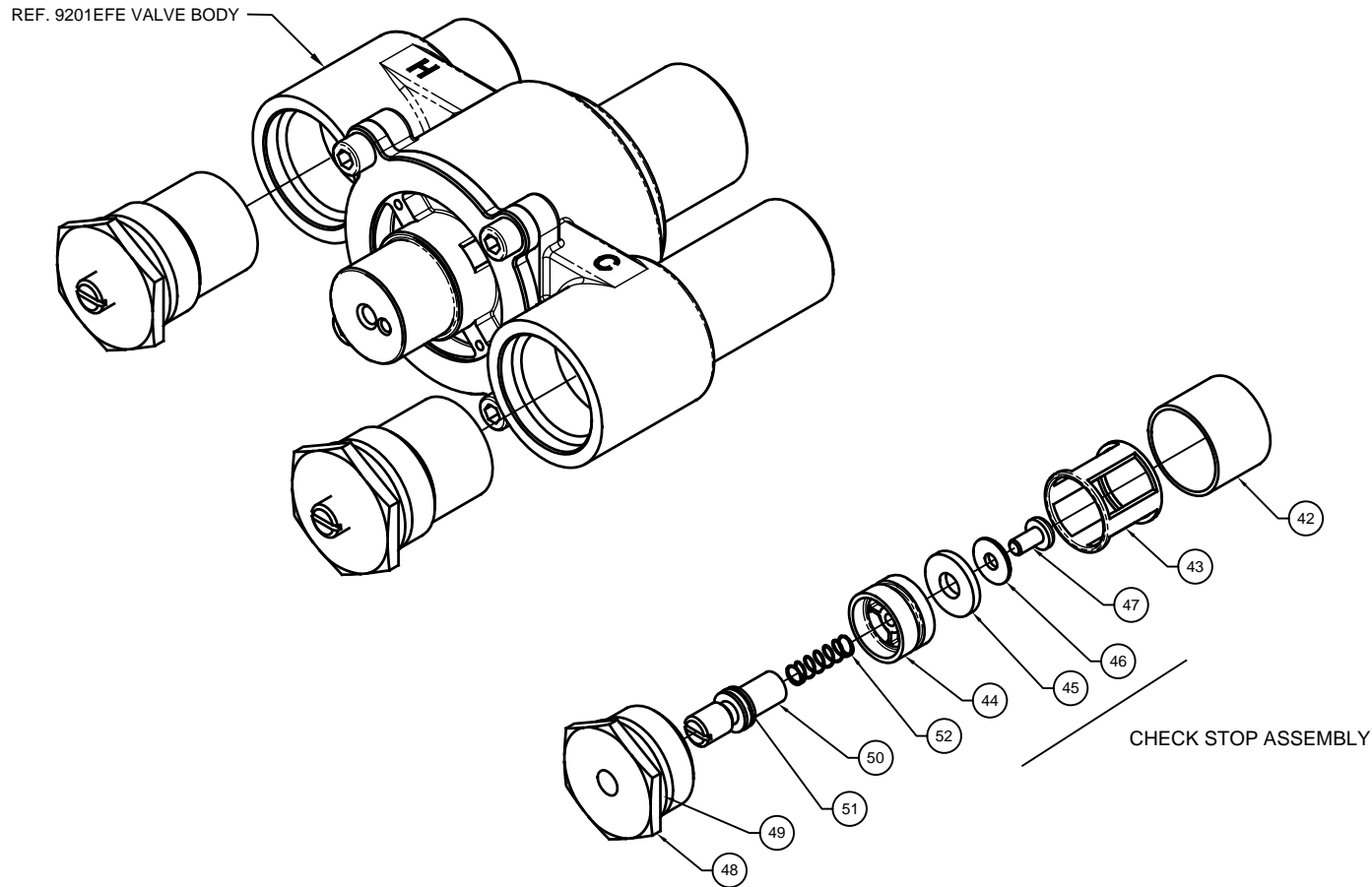

NOTE: HOT AND COLD CHECK STOPS ARE IDENTICAL. KIT INCLUDES BOTH.

**VRK01EFE.C CHECK STOPS REPAIR KIT
SHOWN ON THIS SHEET**

VRK01EFE.C CHECK STOPS REPAIR KIT				
ITEM #	SUB ASSEMBLY	QTY	DESCRIPTION	VRK01EFE.E BASIC MAINT. KIT
48	N/A	2	CHECK STOP COVER BONNET	
49	N/A	2	O-RING DASH# 215 (1.046 ID X .139 W)	INCLUDED
51	N/A	2	O-RING DASH# 012 (.364 ID X .070 W)	INCLUDED
50	N/A	2	STEM CHECK STOP ADJUST. SCREW	
52	N/A	2	SPRING	
44	CHECK STOP ASSY	2	POPPET (NO O-RING)	
45	CHECK STOP ASSY	2	WASHER EPDM	
46	CHECK STOP ASSY	2	WASHER SST	
47	CHECK STOP ASSY	2	SCREW SST 10-24	
43	N/A	2	CAGE SLEEVE	
42	N/A	2	MESH SCREEN SST	

		1455 KLEPPE LANE SPARKS, NEVADA 89431 (775) 359-4712 FAX (775) 359-7424 E-MAIL: HAWS@HAWS.CO.COM WEBSITE: WWW.HAWS.CO.COM	
		ECN NO. 5426 DRAWN: DP APPROVED: NE	REVISED PER: ECN: 5426 DATE: 05/13/19 DATE: 05/21/19
		PART NUMBER 0510000953	REVISION 1
SCALE: N/A		DRAWING TYPE: INSTALLATION	SIZE: A SHEET 3 OF 3