

# Tub & Shower Fittings 150-LADCP

## Product Type

Auto-Drain® hose and hand spray, 1.5 GPM

## Features & Specifications

- 1.5 GPM (5.7 L/min)
- 1.5 GPM hand spray with pause control; two 34" stainless steel hoses with Auto-Drain®
- Wall-mounted hand spray holder
- Hand spray with pause control, 1.5 GPM max.
- Complies with the requirements of the Buy American Act of 1933.



## Performance Specification

- Rated Operating Pressure: 40-125 PSI
- Rated Operating Temperature: 40-120°F

## Warranty

- 5-Year Limited Cartridge Warranty
- Lifetime Limited Faucet Warranty
- 1-Year Limited Finish Warranty

## Codes & Standards

-  ASME A112.18.1/CSA B125.1
-  ADA ANSI/ICC A117.1
-  Certified to WaterSense by ICC-ES

Job Name \_\_\_\_\_

Item Number \_\_\_\_\_

Section/Tag \_\_\_\_\_

Model Specified \_\_\_\_\_

Architect \_\_\_\_\_

Engineer \_\_\_\_\_

Contractor \_\_\_\_\_

Submitted as Shown       Submitted with Variations

Date \_\_\_\_\_



**Architect/Engineer Specification**

Chicago Faucets No. 150-LADCP, Auto-Drain® hose assembly, 1.5 GPM (5.7 L/min) hand spray with pause control; two 34" stainless steel hoses with automatic hose drain. Must be used in combination with inline check valves to comply with ASSE 1014. This product meets ADA ANSI/ICC A117.1 requirements

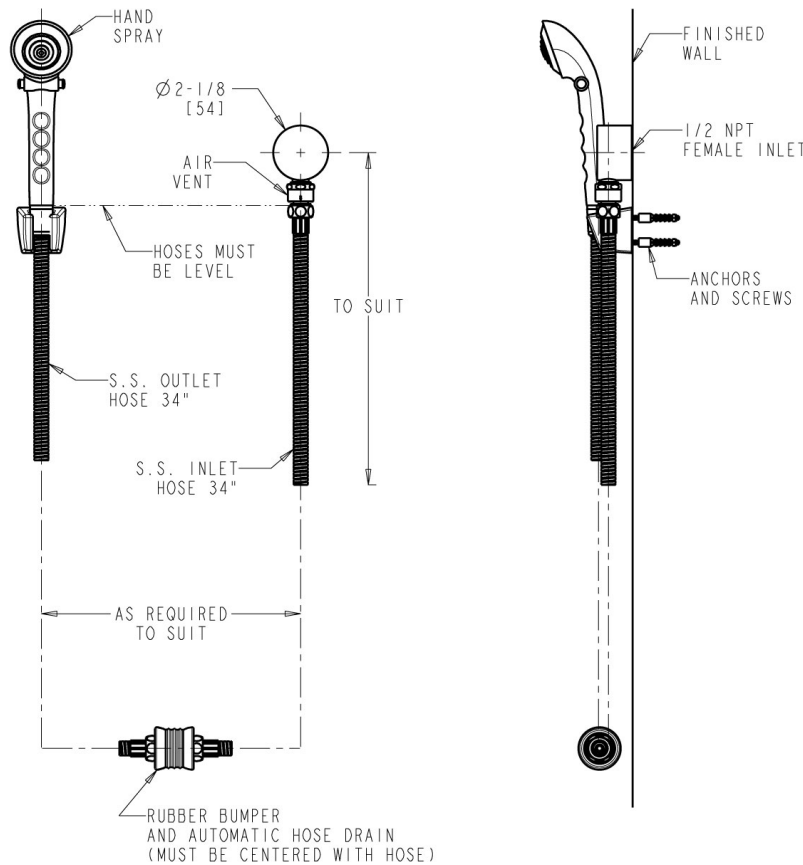

**Operation and Maintenance**

Installation should be in accordance with local plumbing codes. Flush all pipes thoroughly before installation. After installation, remove spout outlet or flow control and flush faucet thoroughly to clear any debris. Care should be taken when cleaning the product. Do not use abrasive cleaners, chemicals or solvents as they can result in surface damage. Use mild soap and warm water for cleaning and protecting the life of Chicago Faucet products. For specific operation and maintenance refer to the installation instructions and repair parts documents that are located at [www.chicagofaucets.com](http://www.chicagofaucets.com).

\*NOTE: Maximum temperature for Thermal Shock Remediation - 180°F for up to three hours. Maximum concentration for Chlorine Shock Remediation - 200 PPM for three hours or 50 PPM for 24 hours. Continual use of the products at elevated temperatures may shorten the life of the product and void the Chicago Faucets warranty. All necessary precautions must be taken to ensure user safety if high temperature flushing of the domestic water system is undertaken. Please note that operating faucets above their rated maximum supply temperature is a safety risk and plumbing code violation in most states. Therefore, Chicago Faucets does not recommend this practice.

Chicago Faucets, member of the Geberit Group, is the leading brand of commercial faucets and fittings in the United States, offering a complete range of products for schools, laboratories, hospitals, office buildings, food service, airports and sport facilities. Call 1.800.TECTRUE or 1.847.803.5000 Option 1 for installation or other technical assistance.



2100 South Clearwater Drive  
Des Plaines, IL  
P: 847/803-5000  
F: 847/803-5454  
Technical: 800/TEC-TRUE  
[www.chicagofaucets.com](http://www.chicagofaucets.com)