

Accessories & Parts

131-LCFMJKABRCF

Product Type

Thermostatic mixing valve for single or multiple faucet installations

Features & Specifications

- Adjustment cap with locking feature
- Compliant with ASSE 1070/ASME A112.1070/CSA B125.70 when installed with two certified check valves
- Brass body construction with corrosion-resistant internal components, includes plastic wall bracket
- Standard 3/8" compression inlets and outlet
- Less check valves for Patient Care Applications
- ECAST® design provides durable cast brass construction with total lead content equal to or less than 0.25% by weighted average
- Complies with the requirements of the Buy American Act of 1933.

Warranty

- 1-Year Limited Cartridge Warranty
- Lifetime Limited Faucet Warranty
- 1-Year Limited Finish Warranty
- 1-Year Limited Material Warranty

Codes & Standards

-  NSF/ANSI/CAN 61, Section 9

Job Name _____

Item Number _____

Section/Tag _____

Model Specified _____

Architect _____

Engineer _____

Contractor _____

Submitted as Shown Submitted with Variations

Date _____

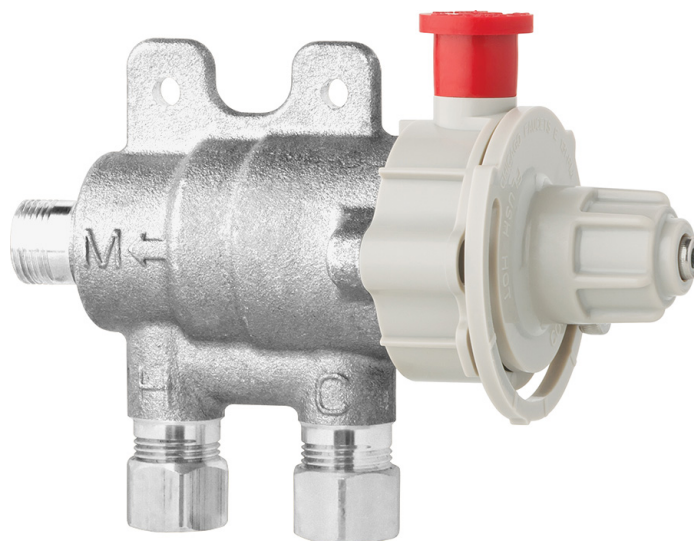

ECAST

ECAST products are intended for installation where state laws and local codes mandate lead content levels or in any location where lead content is a concern.



2100 South Clearwater Drive
Des Plaines, IL
P: 847/803-5000
F: 847/803-5454
Technical: 800/TEC-TRUE
www.chicagofaucets.com

Architect/Engineer Specification

Chicago Faucets No. 131-FMAB, ECAST® Thermostatic Mixing Valve. Installs between the stop valves and the faucet for single or multiple faucet installations. Includes Pipe Flush Mode for high temperature system flushing used in thermal disinfection. Adjustment cap with locking feature. Thermostatic wax element; thermostat controls both hot and cold water. Brass body construction with corrosion-resistant internal components, includes plastic wall bracket. Standard 3/8 compression inlets and outlet. Minimum supply pressure: 30psi (207 kPa); Hot inlet temperature: 120°F to 180°F (49°C to 82°C). Outlet water temperature will be less than hot water inlet temperature. Includes wall bracket. Minimum flow rate: 0.35 gpm (@ min. 20 psi). Maximum flow rate: 4.6 gpm (@ min. 125 psi). Temperature out: 80°F to 120°F (27°C to 49°C). Rough Chrome Finish. ECAST® construction with less than 0.25% lead content by weighted average.

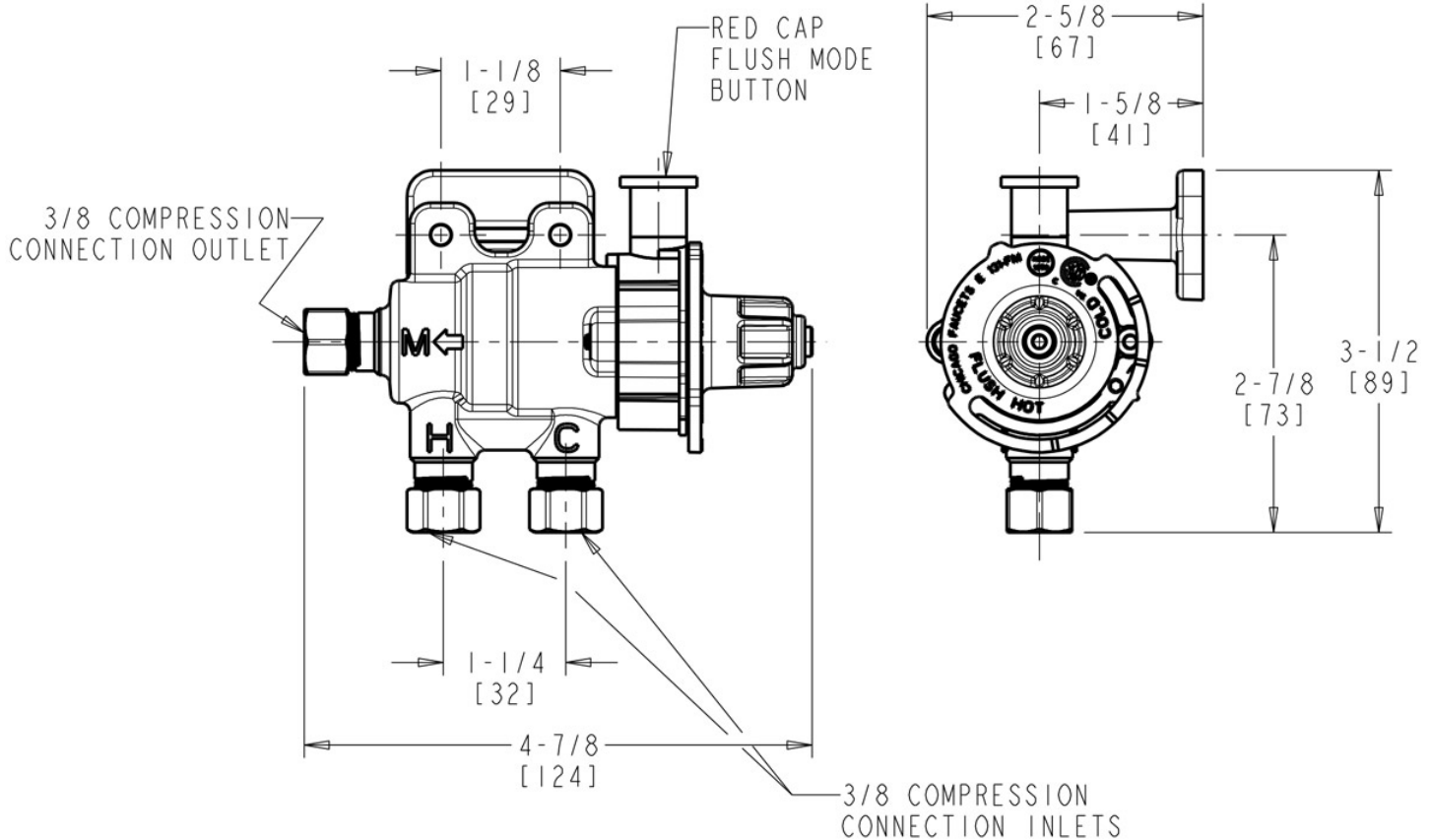

Operation and Maintenance

Installation should be in accordance with local plumbing codes. Flush all pipes thoroughly before installation. After installation, remove spout outlet or flow control and flush faucet thoroughly to clear any debris. Care should be taken when cleaning the product. Do not use abrasive cleaners, chemicals or solvents as they can result in surface damage. Use mild soap and warm water for cleaning and protecting the life of Chicago Faucet products. For specific operation and maintenance refer to the installation instructions and repair parts documents that are located at www.chicagofaucets.com.

Chicago Faucets, member of the Geberit Group, is the leading brand of commercial faucets and fittings in the United States, offering a complete range of products for schools, laboratories, hospitals, office buildings, food service, airports and sport facilities. Call 1.800.TECTRUE or 1.847.803.5000 Option 1 for installation or other technical assistance.

