

Installation

WB1-WB-ER1
WB1-WB-TR1

WB2-WB-ER1
WB2-WB-TR1

WashBar® with Undermount

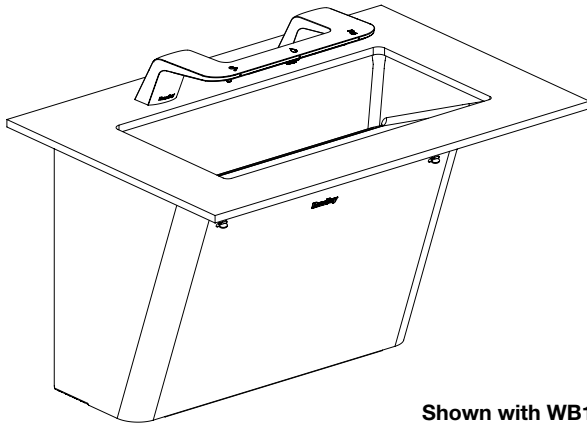

Shown with WB1

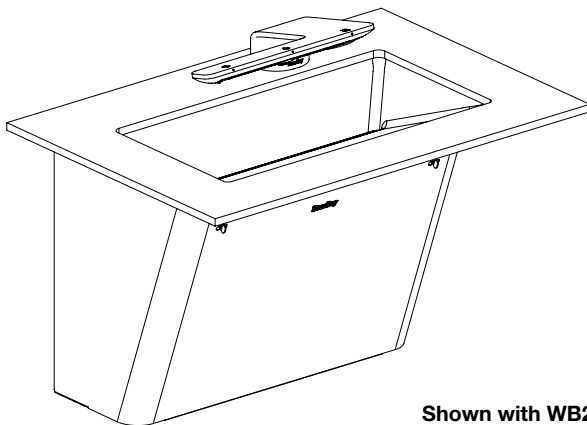

Shown with WB2



[Scan or click code to view
Installation Guide \(French\)](#)



[Scan or click code to view
Installation Guide \(Spanish\)](#)



Read the instructions in this manual before beginning installation. Save these instructions and refer to them for inspection, maintenance, and troubleshooting information.

For questions regarding the operation, installation or maintenance of this product, visit bradleycorp.com or call 800.BRADLEY (800.272.3539).

Product warranties and parts information may also be found under "Resources" on our website at bradleycorp.com.

215-1893 Rev. P: ECO 24-08-017A
© 2025 Bradley
Page 1 of 46 1/17/2025

Table of Contents

Safety Information	2
Supplies Required	2
Components	3
Dimensions	7
Structural Rough-Ins	13
Plumbing and Electrical Rough-In.....	15
Bowl Attachment.....	16
Drain Assembly	19
WashBar Installation	19
Aerator Installation.....	20
Top Fill Soap – Mount Tank Assembly & Control Box	21
Top Fill Soap – Control Box & Soap Supply Connections.....	22
Top Fill Soap – Tank Assembly (Part 1).....	22
Lavatory Mounting to Wall.....	24
Top Fill Soap – Tank Assembly (Part 2).....	25
Bottom Fill Soap – Attach Soap Motor & Soap Container Bracket.....	26
Strainer and Standard Drain Cap	27
Strainer and Slotted Drain Cap.....	27
Dryer Motor Assembly.....	28
Attach Supply Power Enclosure	29
Control Box and Valve Installation	30
Top Fill Soap – Soap Installation.....	31
Bottom Fill Soap – Soap Installation	34
Electrical Connections – Brushless Motors.....	36
Adjust Temperature with Water Running.....	37
Access Panel	38
Master Control Box.....	39
Software Update	43
Displaying Software Revision & Cycle Counts on LCD Display	43
Cleaning and Maintenance	44
Liquid Soap Recommendations and Dispenser Maintenance.....	46

P.O. Box 309
Menomonee Falls, WI 53052 USA
800 BRADLEY (800 272 3539)
+1 262 251 6000
bradleycorp.com



A WATTS Brand

Safety Information

WARNING

Make sure that all water supply lines have been flushed and then completely turned off before beginning installation. Debris in supply lines can cause valves to malfunction.

Turn OFF electrical power to the electrical outlets, then unplug all electrical units prior to installation. Electrical power **MUST** remain off until installation is complete.

Installer's hardware must be appropriate for wall construction. Wall anchors must have a minimum pull-out rating of 1,000 pounds.

IMPORTANT

Read this entire installation manual to ensure proper installation. When finished with the installation, file this manual with the owner or maintenance department. Compliance and conformity to local codes and ordinances is the responsibility of the installer. Product warranties may be found under "Resources" on our website at www.bradleycorp.com.

Separate parts from packaging and make sure all parts are accounted for before discarding any packaging material. If any parts are missing, do not begin installation until you obtain the missing parts.

For standard height mounting, do not exceed the recommended 33.5" distance from the fixture rim to the finished floor.

Troubleshooting and internal maintenance must be performed by qualified service personnel.

Supplies Required

- 3/8" fasteners and wall anchors for wall bracket (minimum pull-out rating of 1,000 lb)
- (4) #10 fasteners and wall anchors for "S" and "S1" soap tank brackets (minimum pull-out rating of 100 lb)
- (4) #10 fasteners and wall anchors for access panel brackets (minimum pull-out rating of 100 lb)
- (4) #8 fasteners and wall anchors for dryer motor vibration pad (minimum pull-out rating of 100 lb)
- 1/2" hot/cold or tempered stub-out
- 1 1/2" NPT drain stub-out(s)
- (1) dedicated NEMA 5-15R Receptacle, 125V GFCI
- Drill
- Basin wrench
- Tape measure
- Phillips screw driver
- Flat head screw driver
- Level
- 5/16" nut driver
- 5/16" socket (with or without extension)
- Construction adhesive suitable for solid surface, forming a strong permanent bond
- P-trap

Components

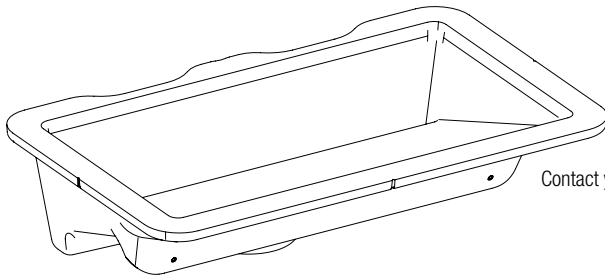

WB-TR1 Bowl (187-350**) WB-ER1 Bowl (187-361**) Contact your Bradley Representative for color and drilling options

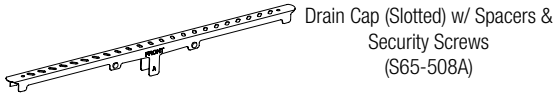

Drain Cap (Slotted) w/ Spacers & Security Screws (S65-508A)

Drain Cap w/ Spacers (S65-508)

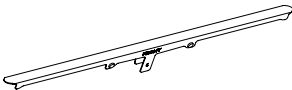

Trough Strainer (173-041) Trough Strainer Screw (160-353)



Deck Clip (269-2765)



Access Panel Bracket (140-1172)

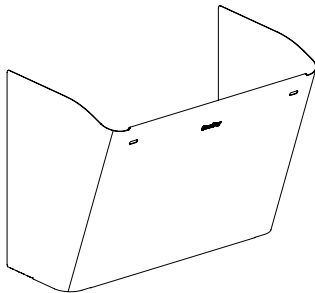

Access Panel Stainless Steel (Standard) (186-1916) Stainless Coated Black (186-1916-BLK)



#10 Access Panel Thumb Screw (160-566)

Access Panel Security Screw Option (S45-2880)

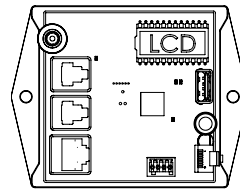

Master Control Box (S83-469 w/Red circuit board) Replaces (S39-845 w/Green circuit board) For mounting screws use #10 x 3/8" (P18-054)

Drain Adapter Prepack (S45-2480)

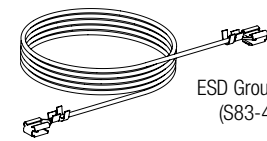
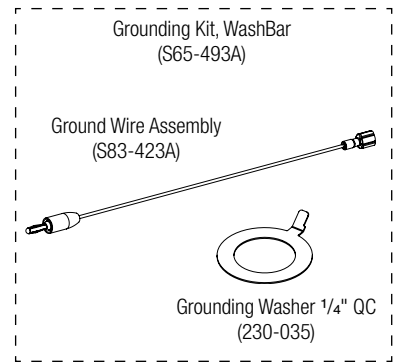
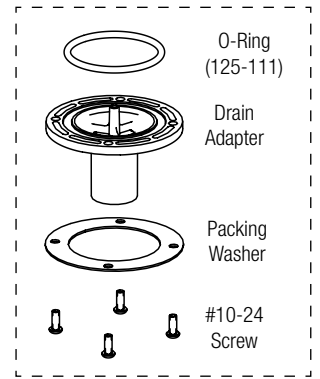

ESD Ground Cable (S83-467-B)

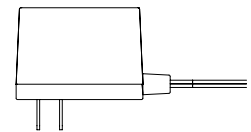

DC Power Adapter (261-147) (Used for brushed motor only)

DC Lead Free Valve Assembly, Single TMA (S08-2401TMA)

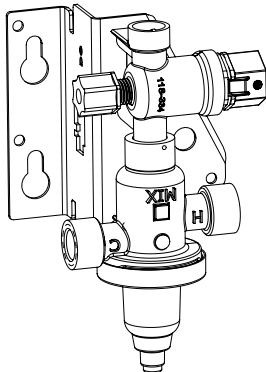

Hose Prepack (S45-2730)

DC Lead Free Valve Assembly, Single TL (S08-2401TL)

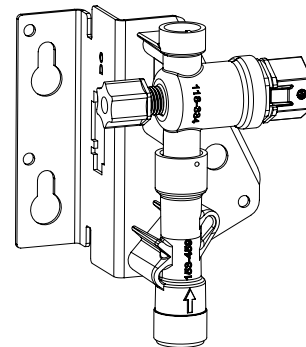

Hose Prepack (S45-2731)

WashBar Components

WB1

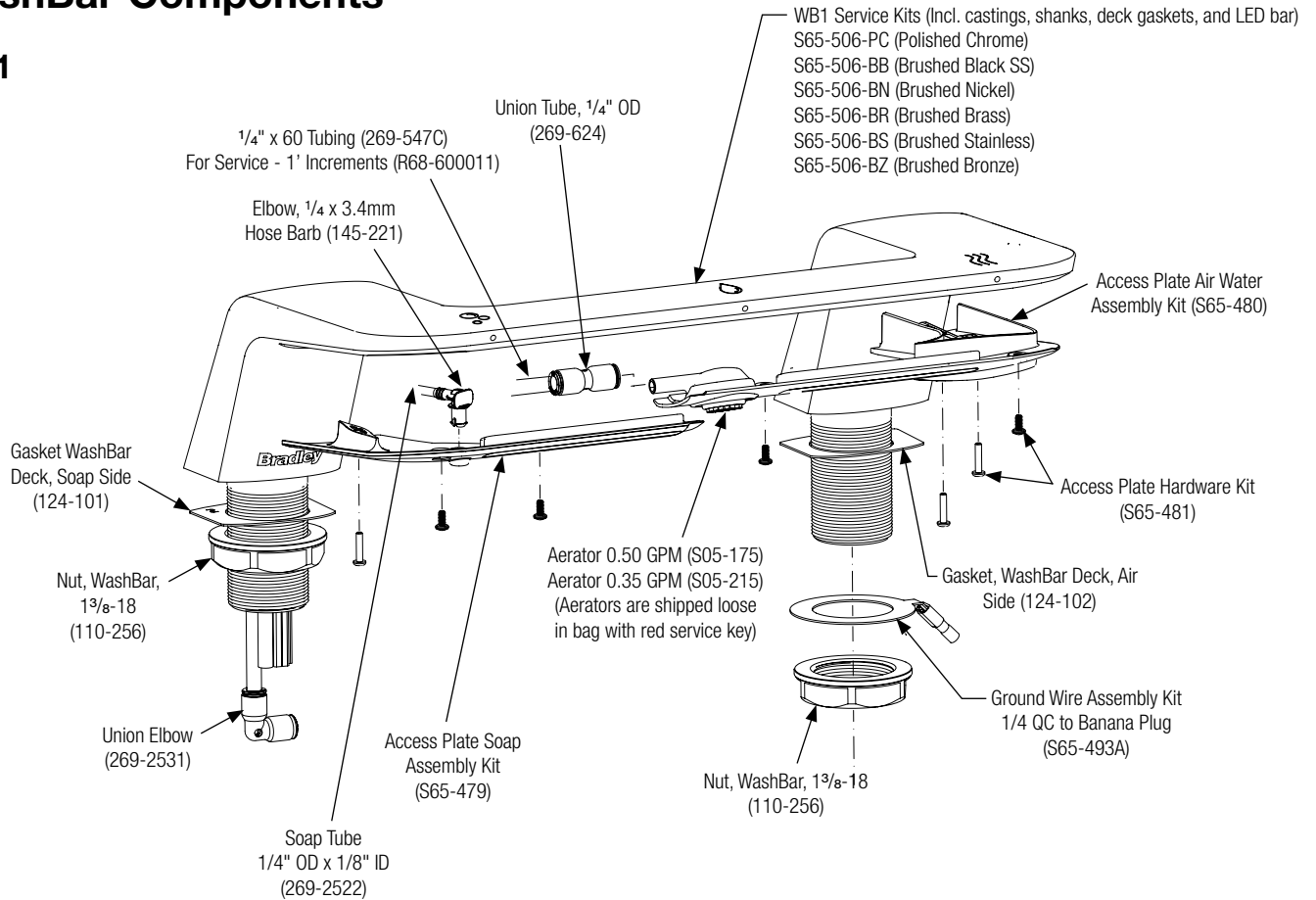

WB2

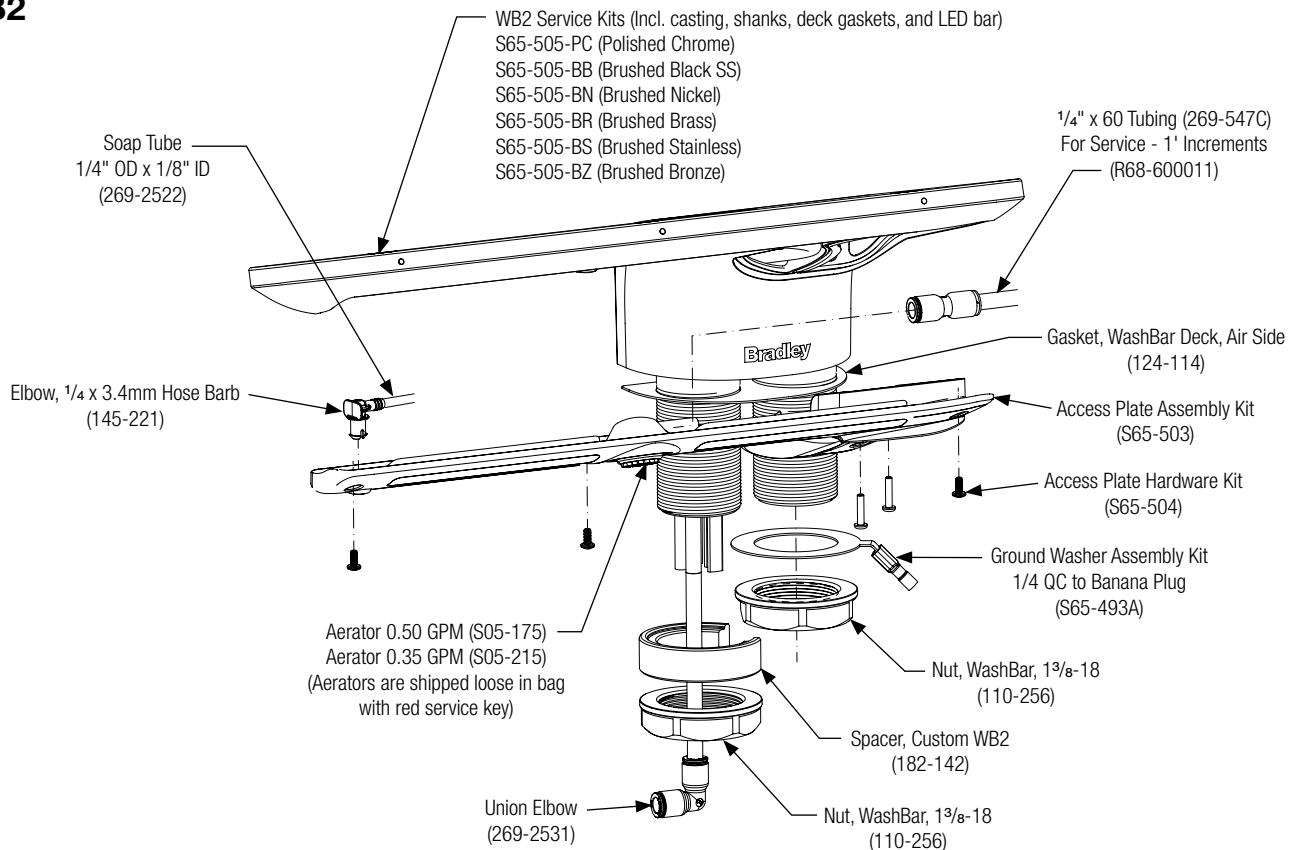

Dryer Motor Components – Brushless Motor (July 2023-present)

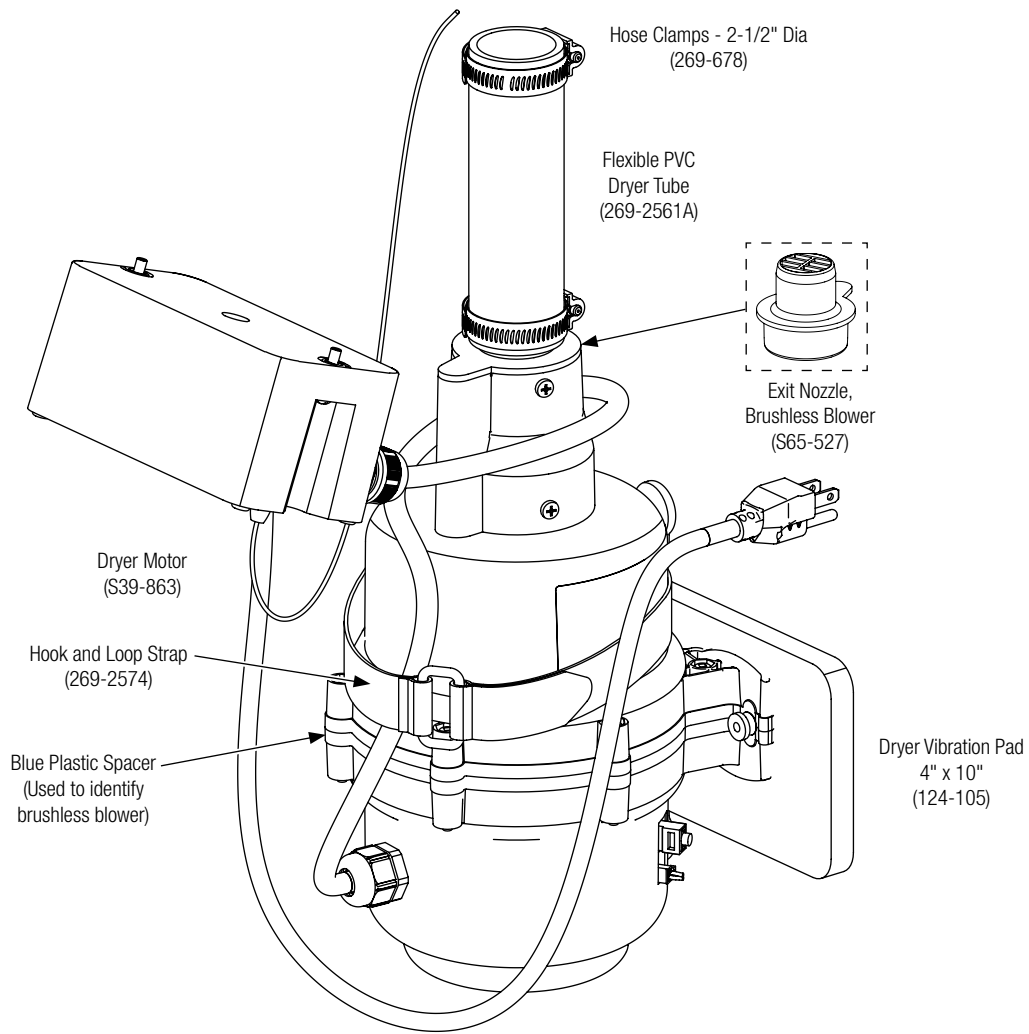

Soap System Components – Top Fill Option

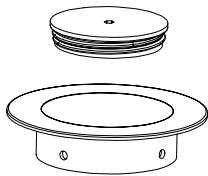
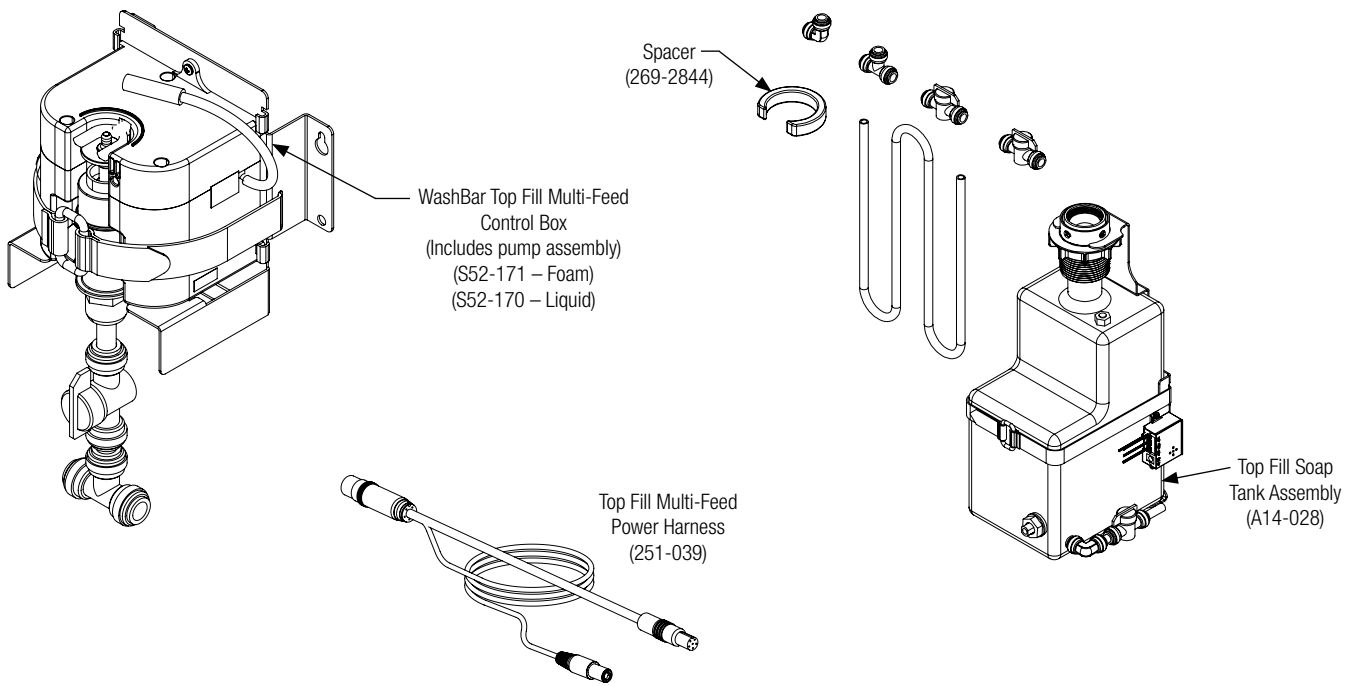

- Multi-Feed Cap and Ring
- A14-027-PC (Polished Chrome)
 - A14-027-BB (Brushed Black SS)
 - A14-027-BN (Brushed Nickel)
 - A14-027-BR (Brushed Brass)
 - A14-027-BS (Brushed Stainless)
 - A14-027-BZ (Brushed Bronze)



- Allen Key, 3 mm
(5 pk)
(P15-530)

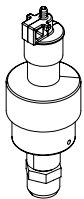

WashBar Top Fill Soap Pump
(Foam w/Tube)
(P15-587)

OR

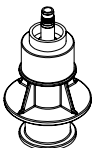

WashBar Top Fill Soap Pump
(Liquid w/Tube)
(P15-565)

Power Supply

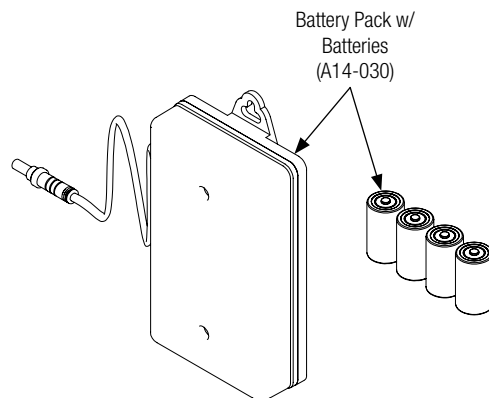

Soap System Components – Bottom Fill Option

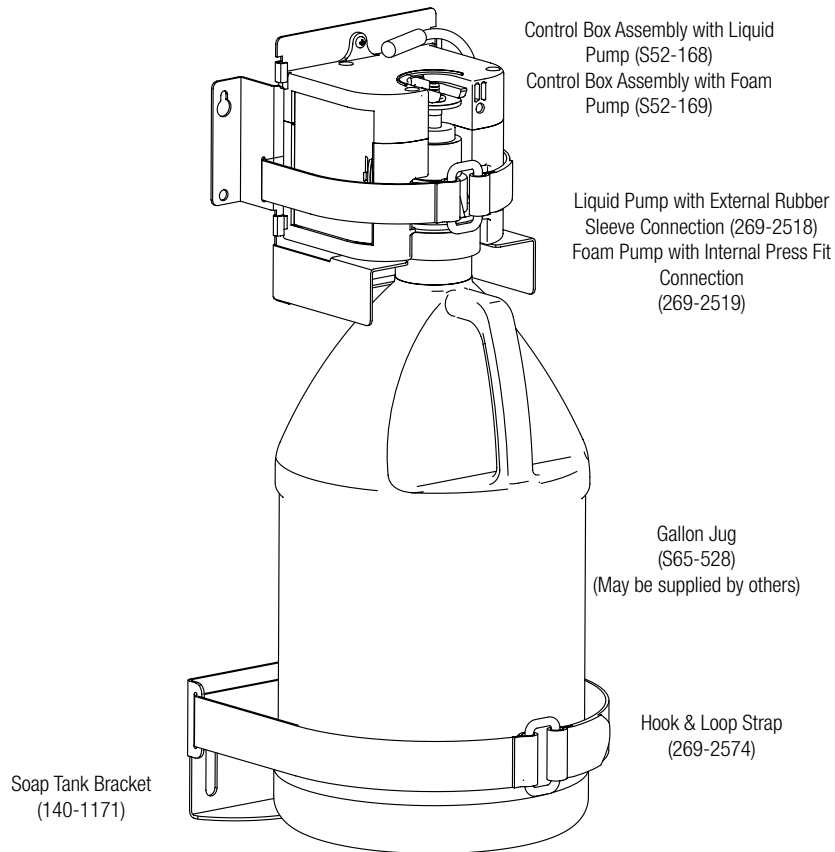

Dimensions

(mm)

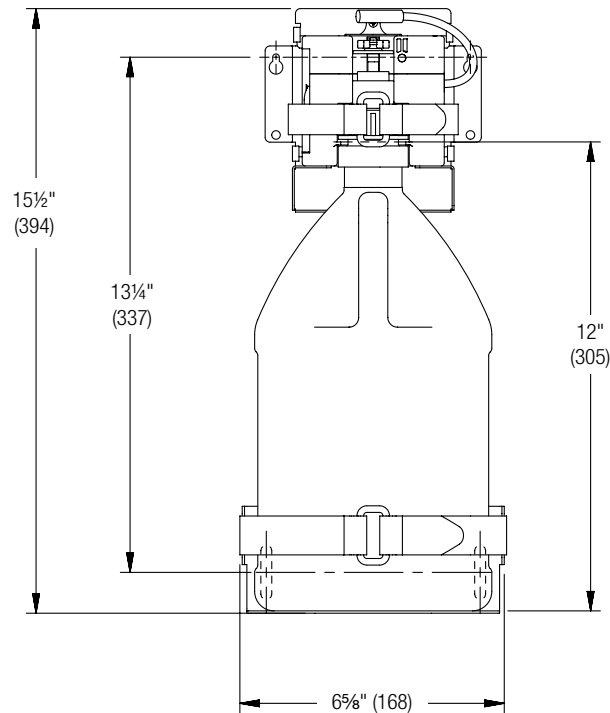

Dimensions – 1-Person Typical Deck Size

(mm)

Top View - WB1

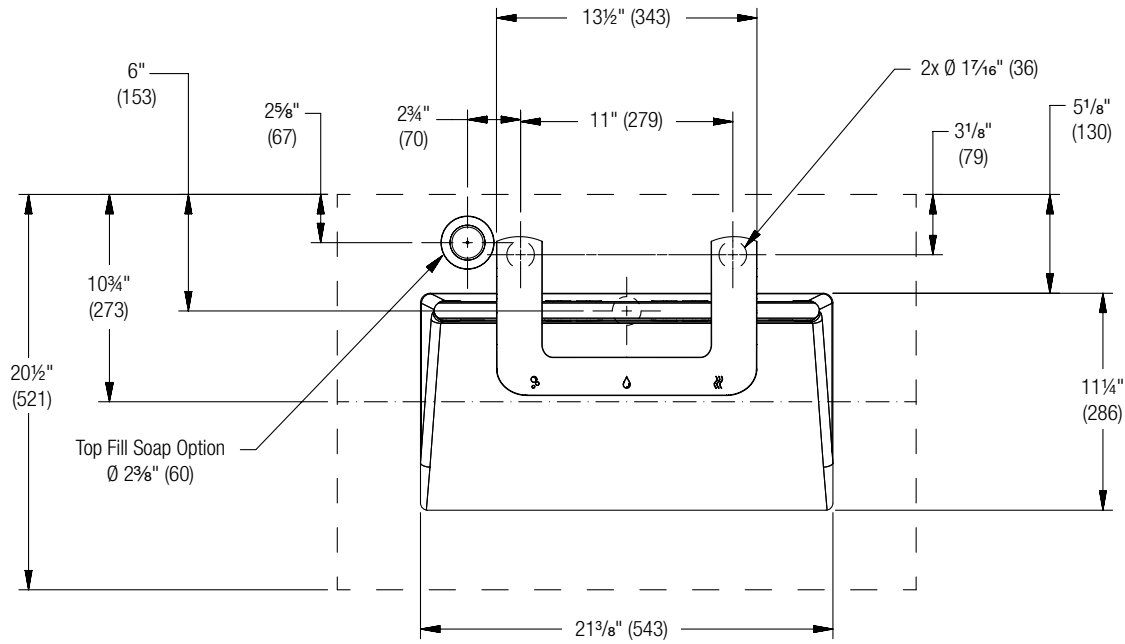

Top View - WB2

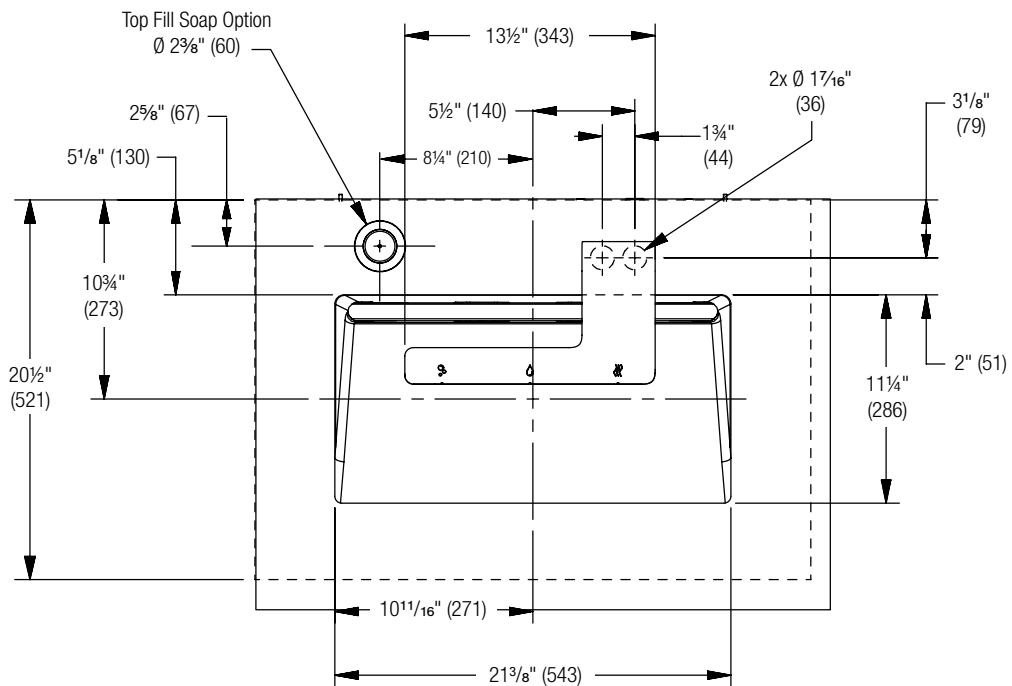

Dimensions – 1-Person Typical Deck Size

(mm)

Front View

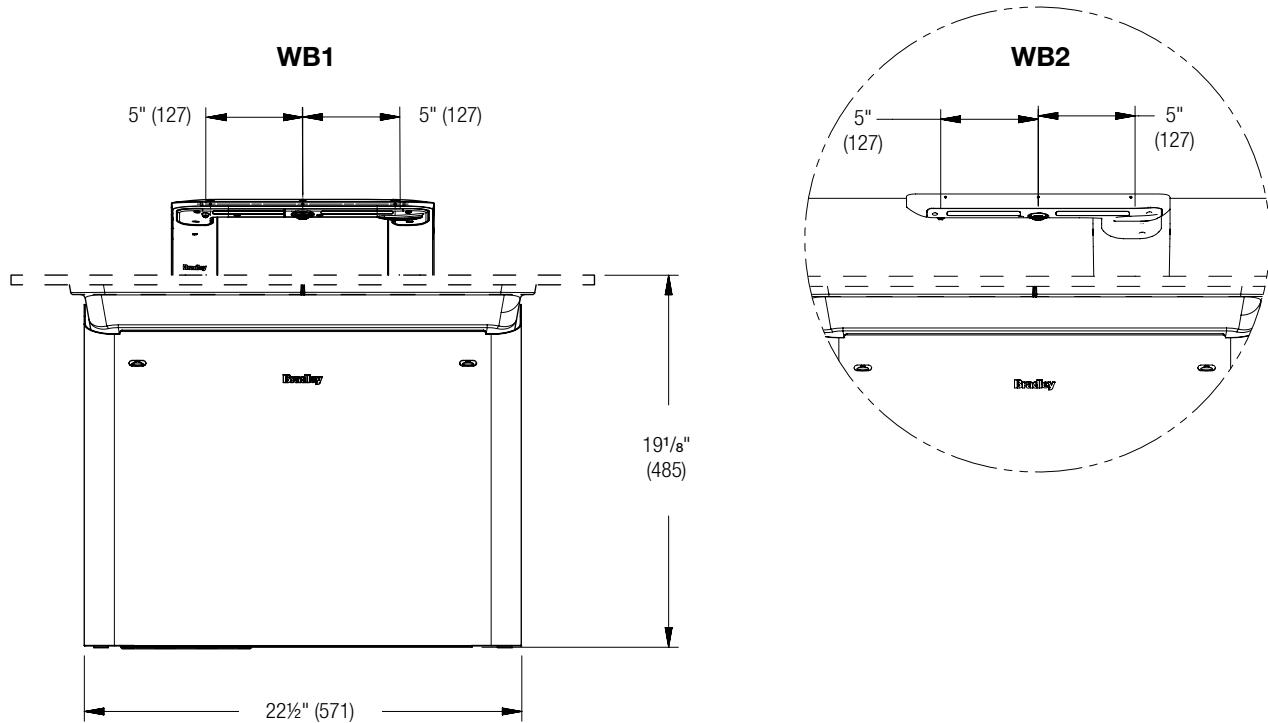

Dimensions – Side View (WB1)

(mm)

Standard Height

Juvenile Height

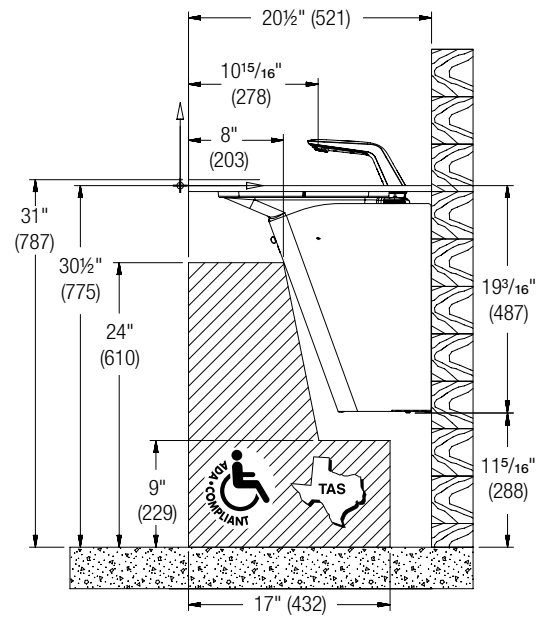
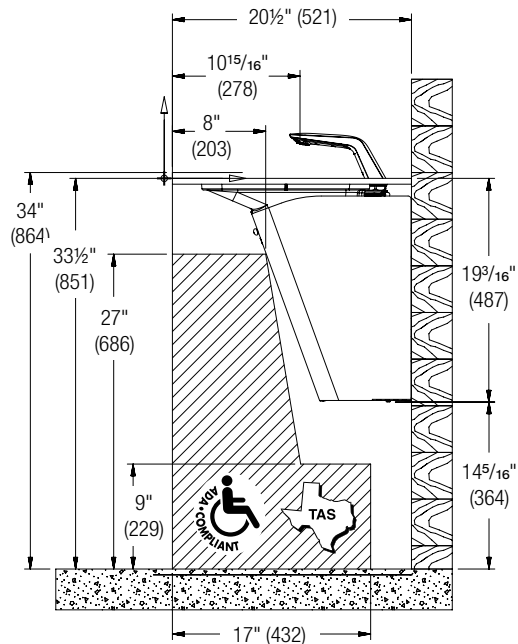

Deck depth must be 20 1/2" minimum for ADA,
Enhanced Reach depth is only 20 1/2"

Deck depth must be 20 1/2" minimum for ADA,
Enhanced Reach depth is only 20 1/2"

Dimensions – Side View (WB1)

(mm)

OBC Height

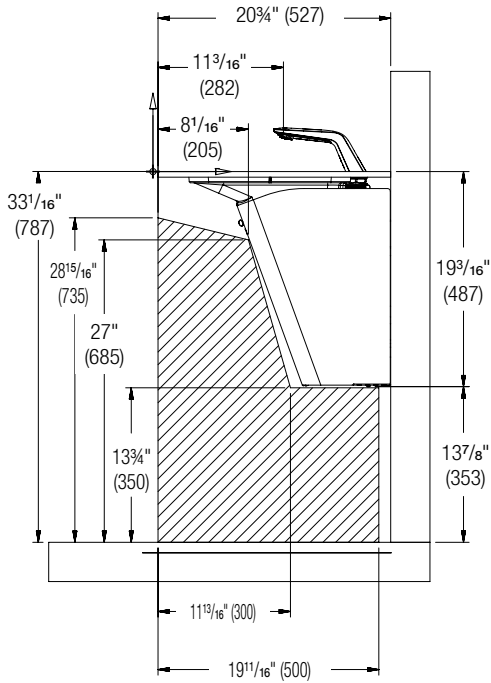

Deck depth must be 20 3/4" (527) minimum for OBC

BCBC Height

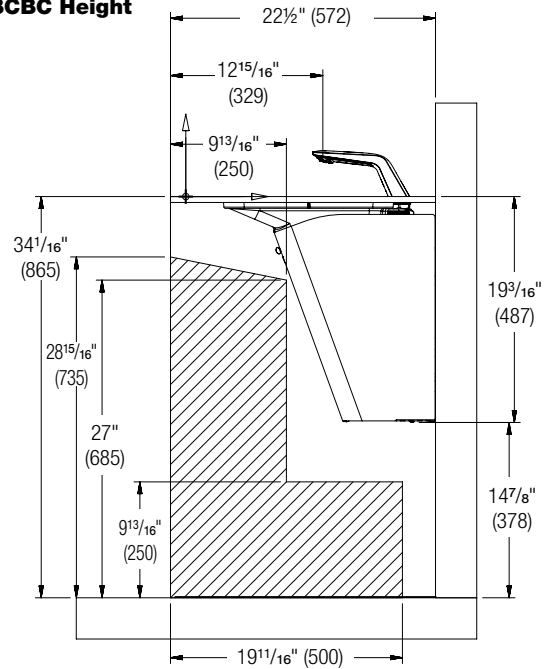

Deck depth must be 22 1/2" (572) minimum for BCBC

CSA Height

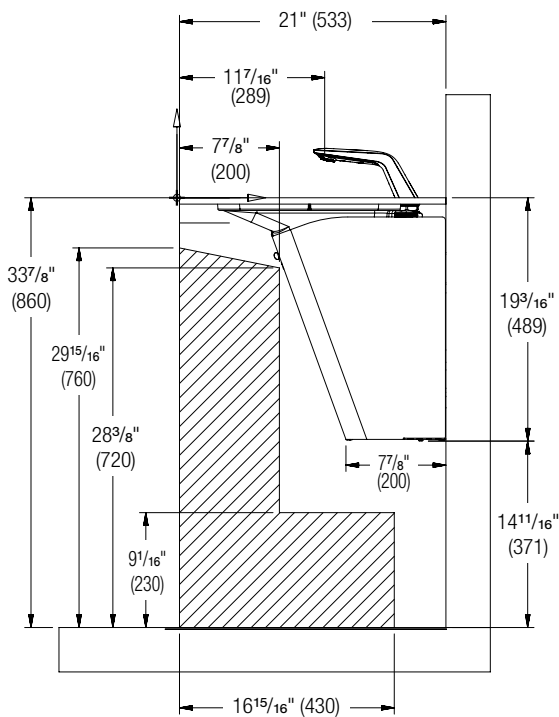

Deck depth must be 21" minimum for CSA

Quebec Height

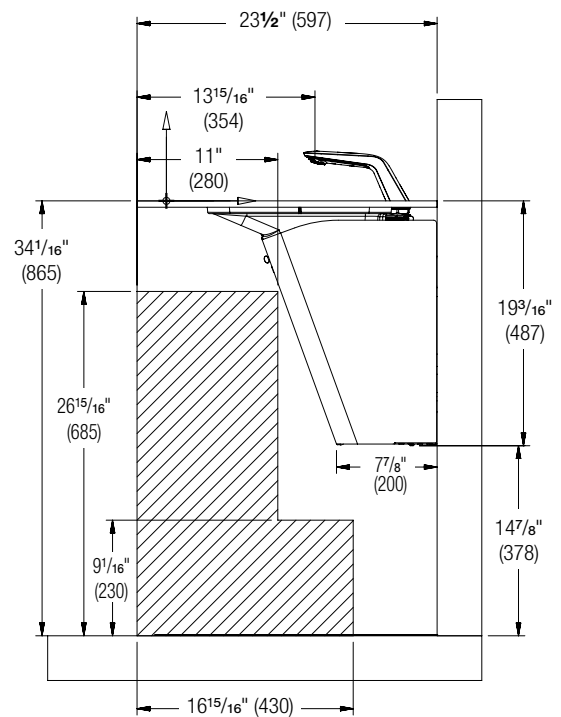

Deck depth must be 23 1/2" (597) minimum for QBC

Dimensions – Side View (WB2)

(mm)

Standard Height

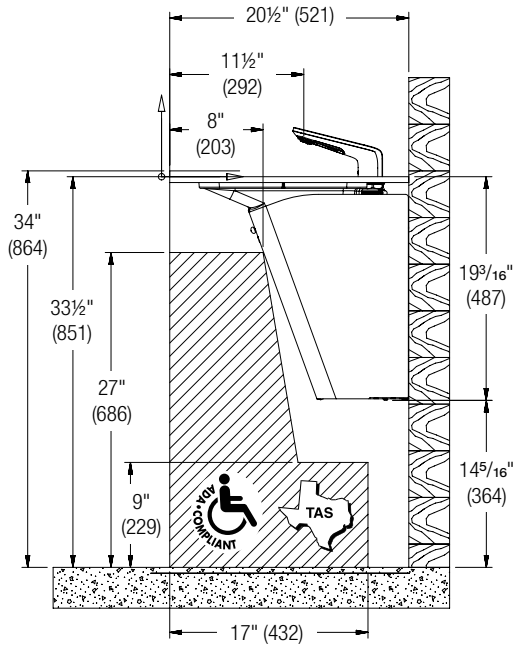

**Deck depth must be 20½" minimum for ADA,
No enhanced reach at minimum depth of 20½"**

Juvenile Height

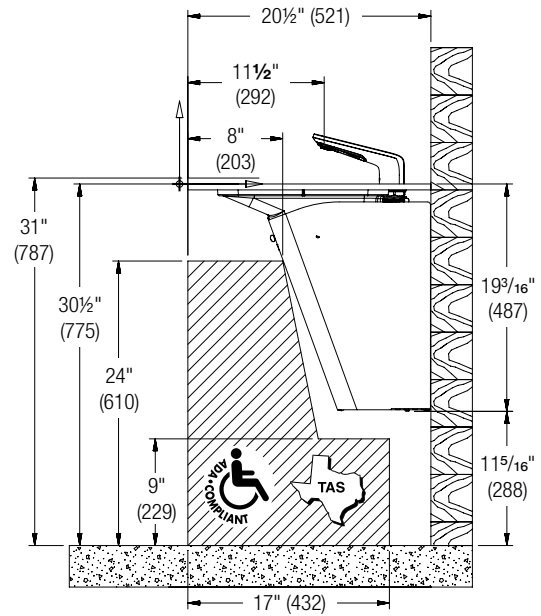

**Deck depth must be 20½" minimum for ADA,
No enhanced reach at minimum depth of 20½"**

Dimensions – Side View (WB2)

(mm)

OBC Height

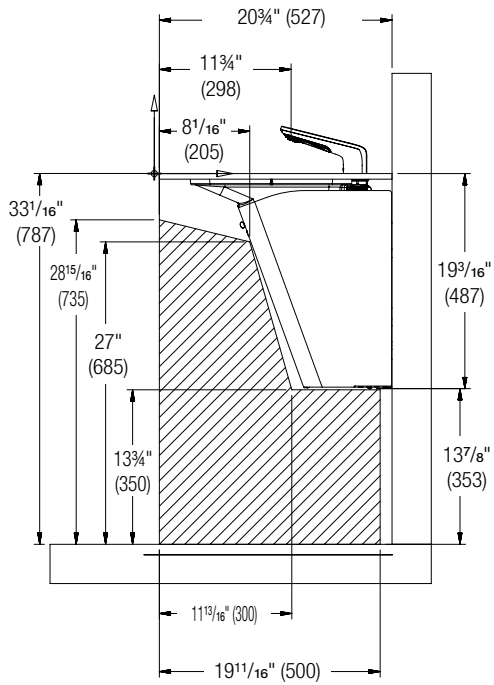

Deck depth must be 20 3/4" (527) minimum for OBC

BCBC Height

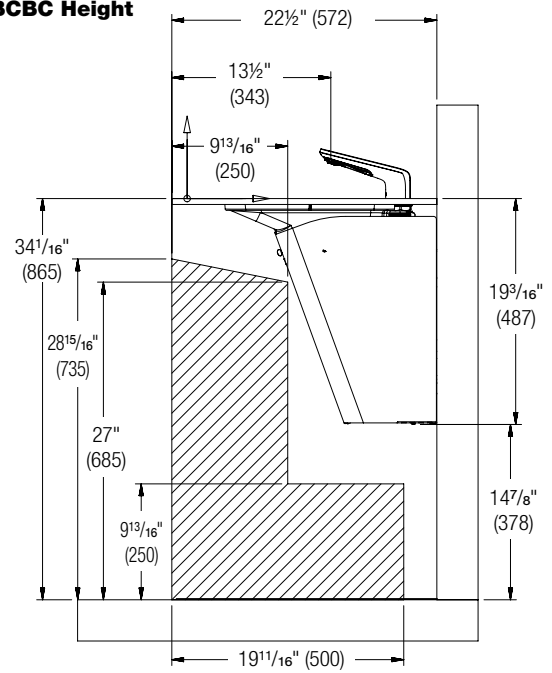

Deck depth must be 22 1/2" (572) minimum for BCBC

CSA Height

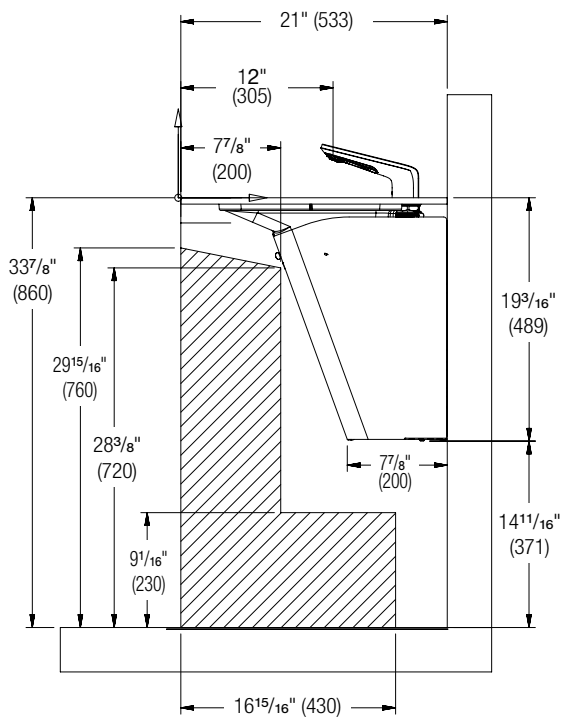

Deck depth must be 21" minimum for CSA

Quebec Height

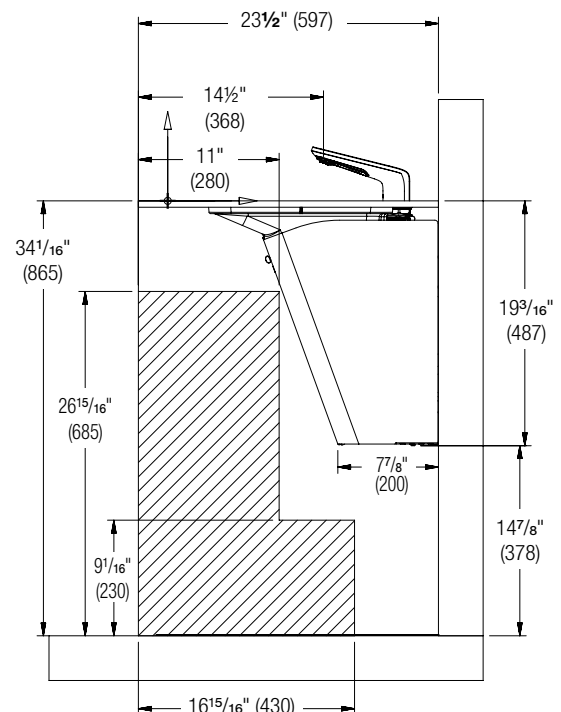

Deck depth must be 23 1/2" (597) minimum for QBC

Structural Rough-In for Top Fill Soap

(mm)



Typical Rough-In for single WB-TR1 or WB-ER1 bowl is shown. Other multiple bowl rough-ins are similar.

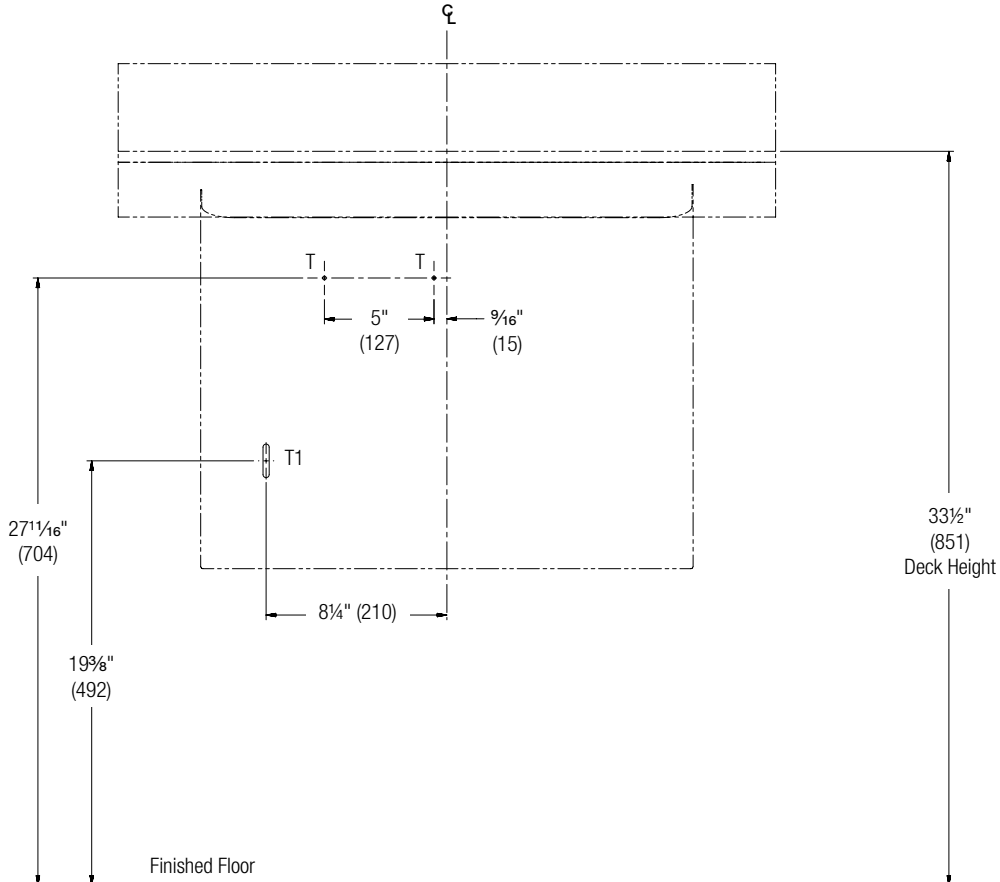

CODE	DESCRIPTION	QTY.
T	#10 Wall Anchors for Top Fill Soap Tank Bracket (100 lb pull out force)	1
T2	#10 Wall Anchors for Top Fill Soap Control Box Bracket	2

RIM HEIGHT	VERTICAL HEIGHT ADJUSTMENTS	FIXTURE STYLE
34"	No Adjustment	Standard Height ADA and TAS
31"	Subtract 3"	Juvenile ADA and TAS
33 1/16"	Subtract 1 5/16"	OBC
34 1/16"	Add 1/16"	BCBC and QBC
33 7/8"	Subtract 1/8"	CSA

Structural Rough-In for Bottom Fill Soap

(mm)



Typical Rough-In for single WB-TR1 or WB-ER1 bowl is shown. Other multiple bowl rough-ins are similar.

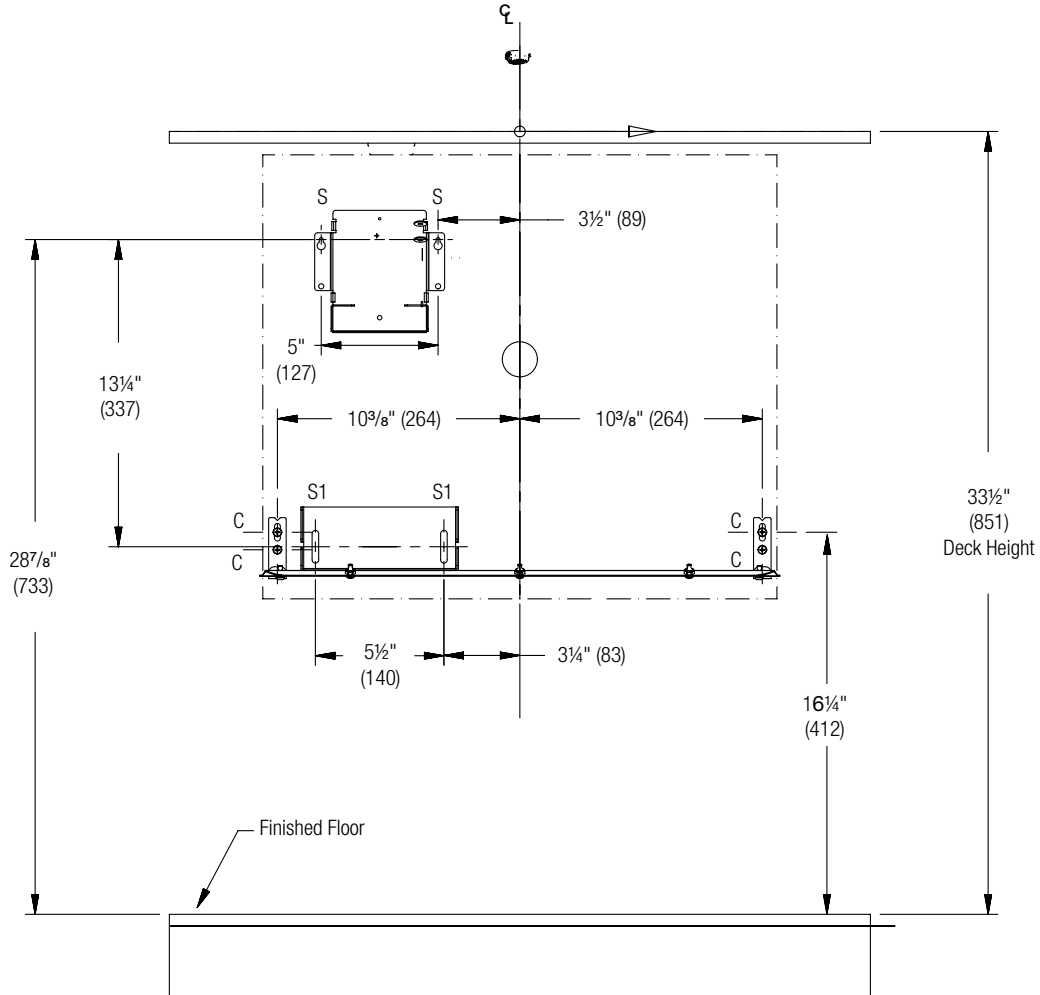

CODE	DESCRIPTION	QTY.
C	Install wall anchor with a minimum pull-out force of 100 lb per local codes at locations shown	4
S	#10 Wall Anchors for Bottom Fill Soap Control Box Bracket	2
S1	#10 Wall Anchors for Bottom Fill Soap Tank Bracket (100 lb pull out force)	2

RIM HEIGHT	VERTICAL HEIGHT ADJUSTMENTS	FIXTURE STYLE
34"	No Adjustment	Standard Height ADA and TAS
31	Subtract 3"	Juvenile ADA and TAS
33 1/16"	Subtract 15/16"	OBC
34 1/16"	Add 1/16"	BCBC and QBC
33 7/8"	Subtract 1/8"	CSA

Plumbing and Electrical Rough-In

(mm)



Mounting for Standard ADA and TAS height shown.



Typical rough-in for single WB-TR1 or WB-ER1 bowl is shown. Other multiple bowl rough-ins are similar.

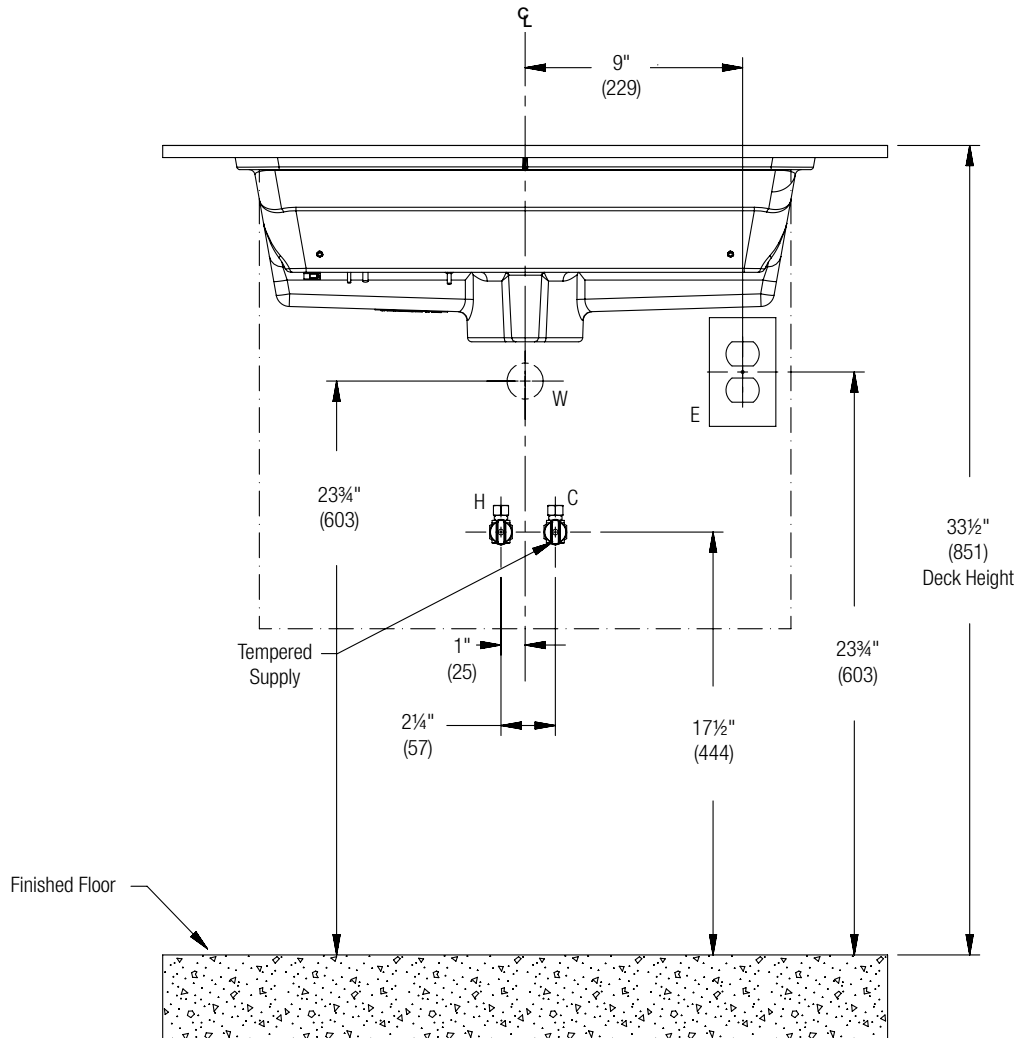

CODE	DESCRIPTION	QTY.
W	1 1/2" NPT Drain, Stub-out 2" from wall	1
H, C	1/2" Nominal (5/8" O.D. Comp.) Hot/Cold supplies, Stub-out 2" from wall	1
E	Dedicated NEMA 5-15R Receptacle, 125V GFCI must be provided, which is properly grounded and no more than 4 ft from the installation of the dryer assembly.*	1

* If no GFCI outlet is provided, contact a licensed electrician to assure proper electrical connections in accordance with local building codes. Troubleshooting and internal maintenance must be performed by qualified service personnel.

1 Bowl Attachment – WB1 & WB2

Cutout Template Guide – WB1 Top Fill Soap (WB-TR1 & WB-ER1)



Hole drilling location for WashBar must be 2.0" from basin cutout as shown.

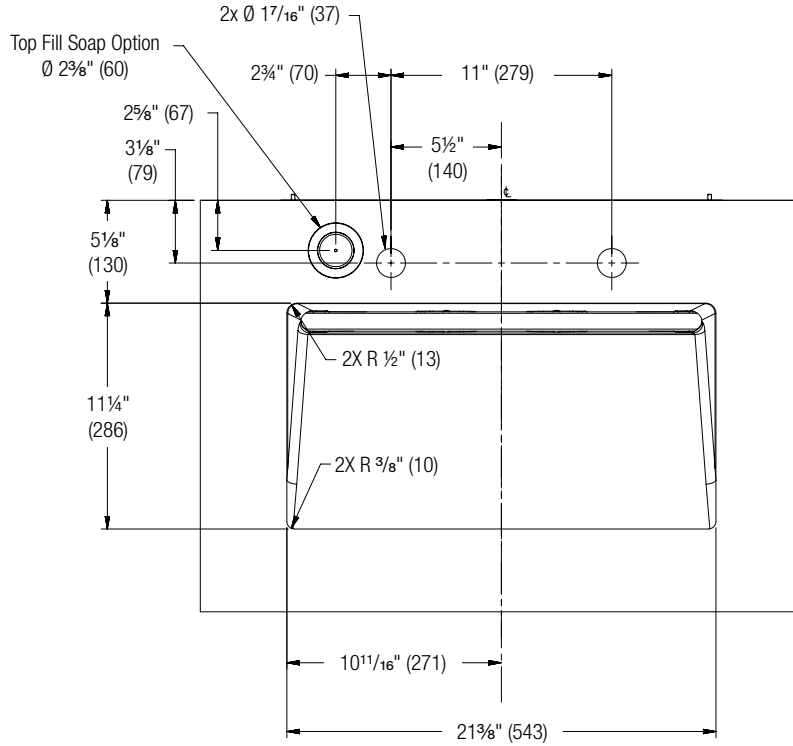

Cutout Template Guide – WB1 Bottom Fill Soap (WB-TR1 & WB-ER1)



Hole drilling location for WashBar must be 2.0" from basin cutout as shown.

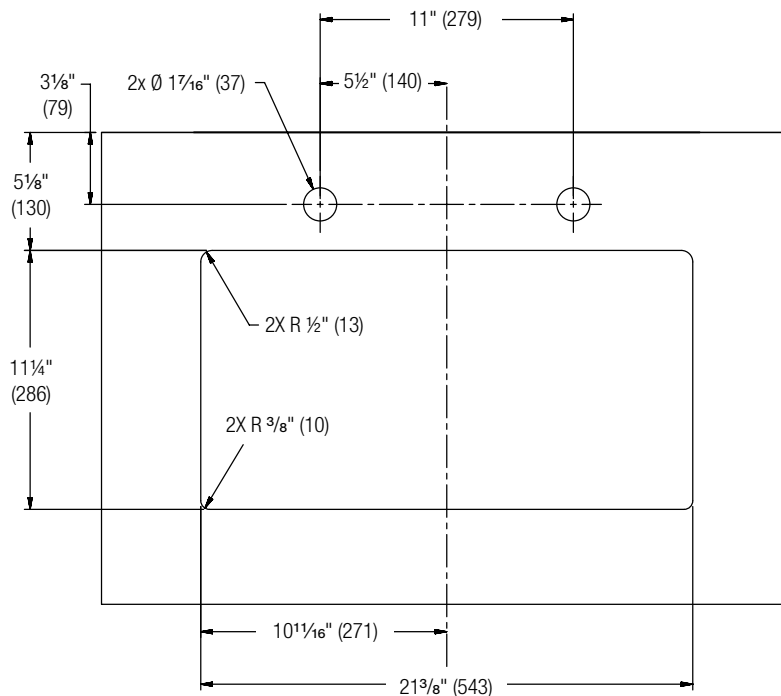

Cutout Template Guide – WB2 Top Fill Soap (WB-TR1 & WB-ER1)



Hole drilling location for WashBar must be 2.0" from basin cutout as shown.

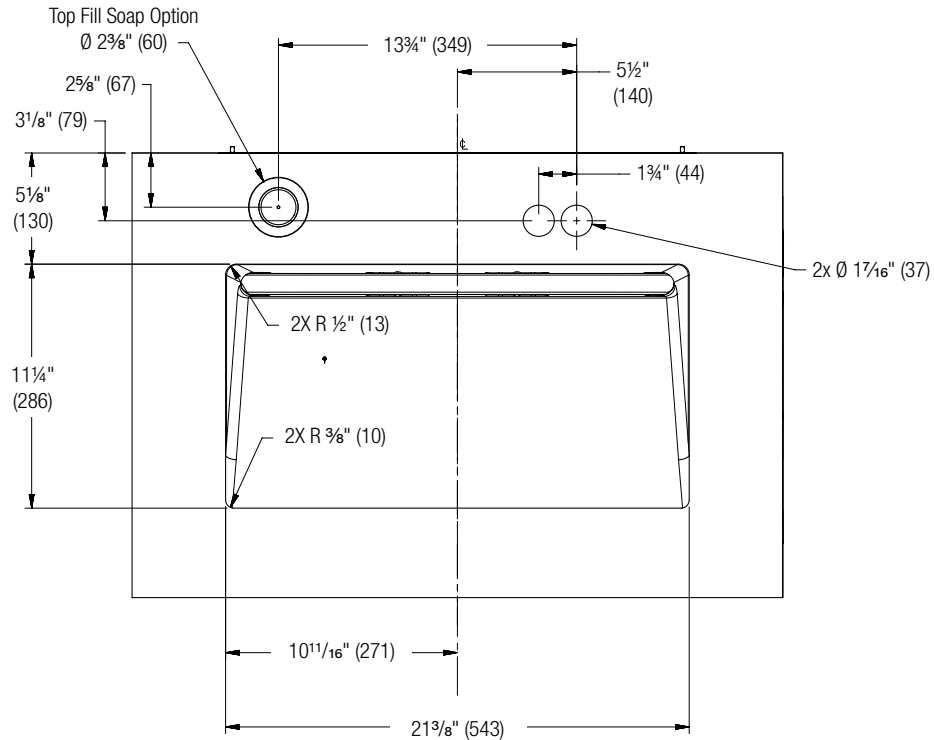

Cutout Template Guide – WB2 Bottom Fill Soap (WB-TR1 & WB-ER1)



Hole drilling location for WashBar must be 2.0" from basin cutout as shown.

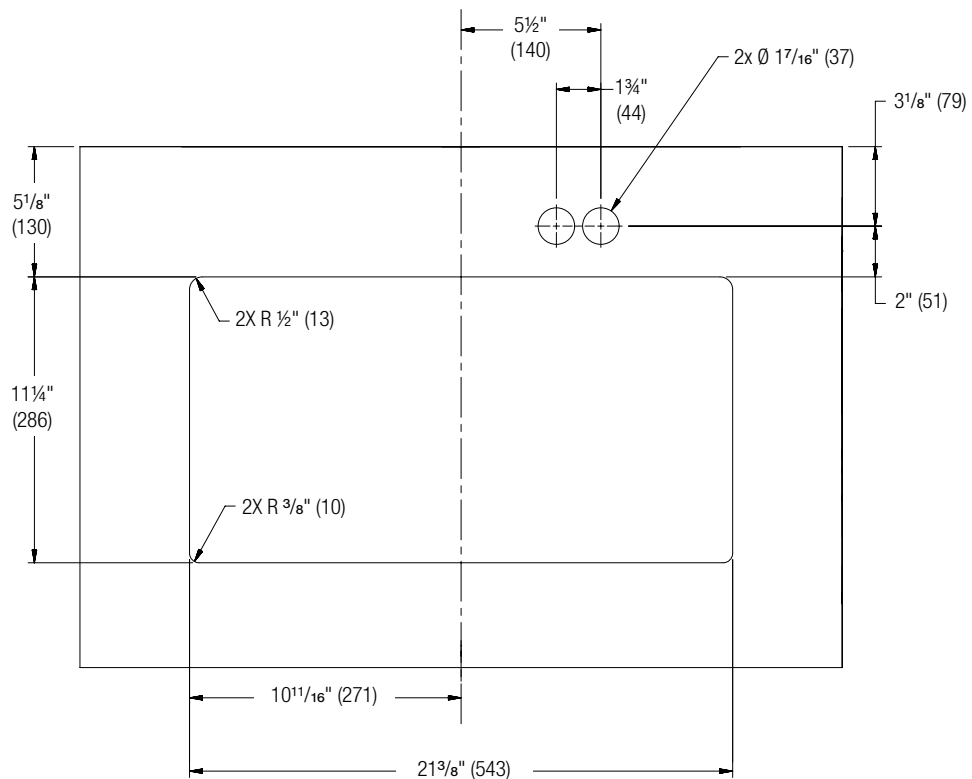

Bowl/Counter Attachment

A

Apply silicone sealant around interior and exterior of the bowl after it is aligned to the deck opening. Allow silicone to cure for 24 hours before use.

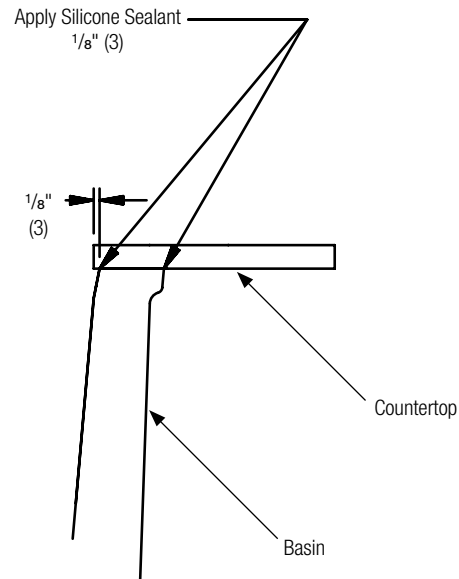

⚠ WARNING If installing the bowl on a pre-installed deck surface, support the bowl during alignment and positioning of the clips to prevent dropping the bowl which may cause damage or personal injury.

A

In the locations shown, use an angle grinder with a standard disc to cut into the deck at a depth of 1/4" for a deck thickness less than 5/8" thick or a depth of 1/2" for a deck thickness of greater than 5/8".

B

Cut slots into the deck at the locations shown below.

C

Align the bowl in the cutout with an 1/8" (3 mm) overhang.

D

Temporarily support the bowl during alignment.

E

Place the clips into the previously cut slots and tighten against the rim of the bowl.

F

Apply generous amount of silicone sealant to the edges of the bowl.

G

Wipe the silicone sealant for a smooth joint.

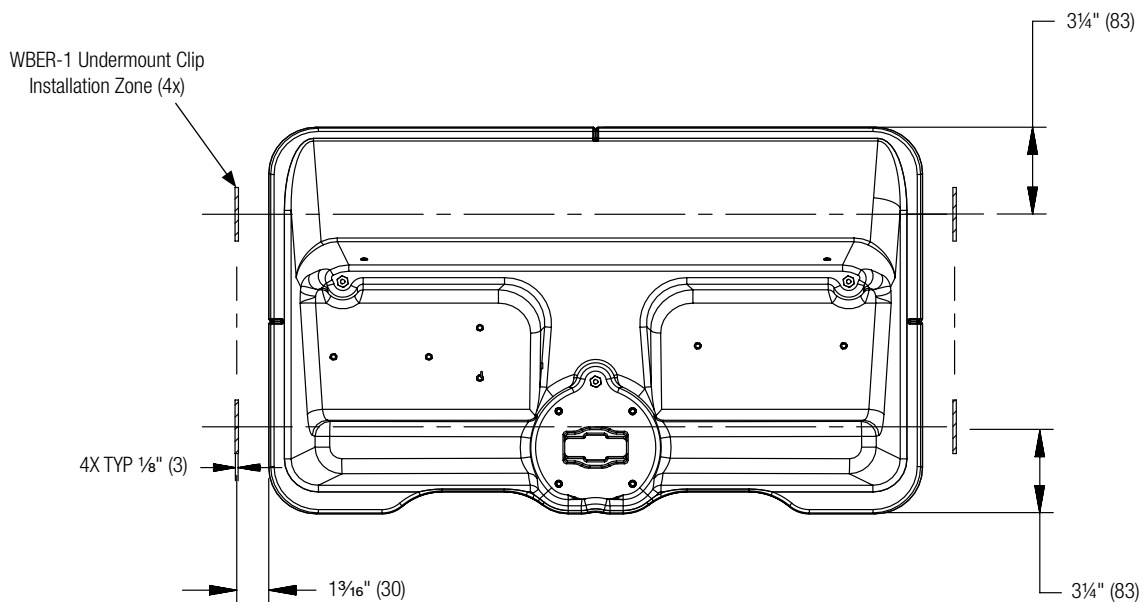



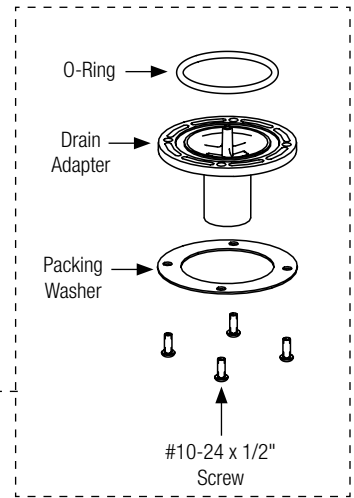
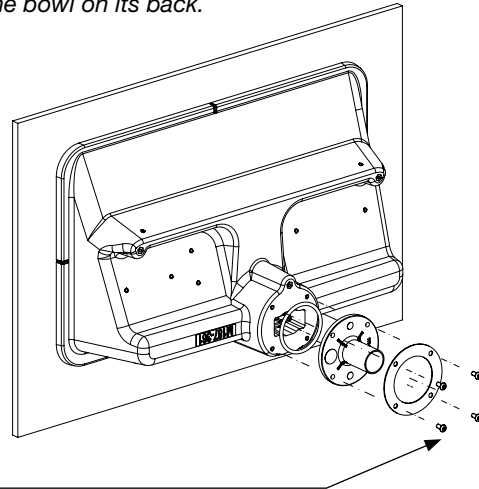

2 Drain Assembly

 For ease of drain installation, lay the bowl on its back.

A Assemble the remaining components as shown and thread the four screws through the drain adapter and into the basin inserts. Ensure the screws compress the drain adapter evenly onto the basin.
NOTICE! Do NOT overtighten drain adapter screws.



3 WashBar Installation

-  WB1 is shown for these instructions.
-  Single station shown; 2 station similar.
-  WashBar comes pre-assembled, with the exception of the aerator.
-  When attaching flexible PVC dryer tube, be sure tube is touching the WashBar nut when complete.

E Connect grounding wire spade terminal end to grounding washer tab. Do not attach grounding wire plug adapter to wall outlet until later in the installation procedure.

D Attach flexible PVC dryer tube to shank using hose clamp. Tighten to 30-35 in-lb using 5/16" socket.

A Position bowl on the floor, upright, as shown.

B Assemble WashBar through basin WashBar holes. Run cables and tubes on left side only.

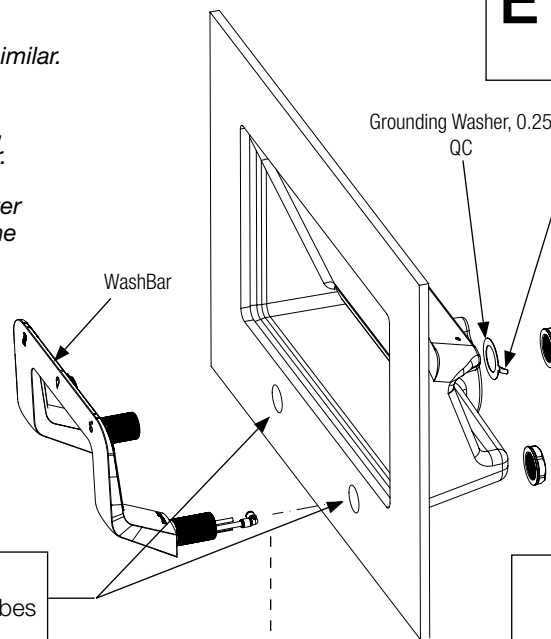

For WB1 & WB2: Secure from underside with (2) nuts and (1) grounding washer (right side only).
C For WB2 Only: Install the custom spacer (182-142) between deck and nut (left side only) with spacer groove side up against deck. Refer to page 4.

F Attach the 1/4" supply tube to the 1/4" union elbow.

4 Aerator Installation – WB1 & WB2



WB1 is shown for these instructions.

A

Carefully thread the aerator into the WashBar casting using the red service key provided. Ensure no leaks after installation.

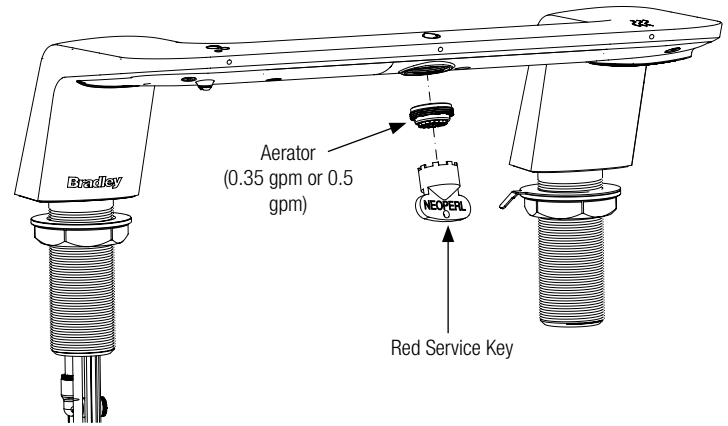



Follow Steps 5–8 for top fill soap option installation instructions.

Skip to Step 8 for bottom fill soap option installation instructions.

5 Top Fill Soap – Mount Tank Assembly & Control Box



Refer to the Structural Rough-In – Top Fill Soap drawing on page 14 before mounting the soap tank assembly and the control box.

A Locate the mounting position for the control box assembly per the rough-in on page 13.

B Ensure the control box assembly is level, and then use a pencil to mark two top mounting hole locations (two bottom mounting holes are optional) on the wall.

C Drill the two 1/4" diameter mounting holes into the wall or surface, using a drill and appropriate drill bit.

D Use the supplied mounting screws (or suitable mounting hardware) to attach the control box assembly in place.



Appropriate fastener anchors and mounting hardware must be used when mounting the control box assembly in the desired surface.

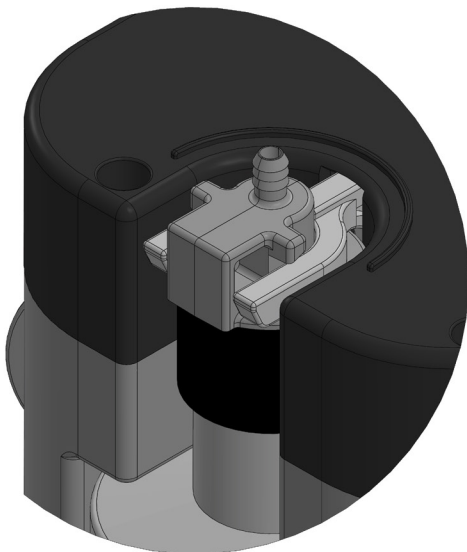
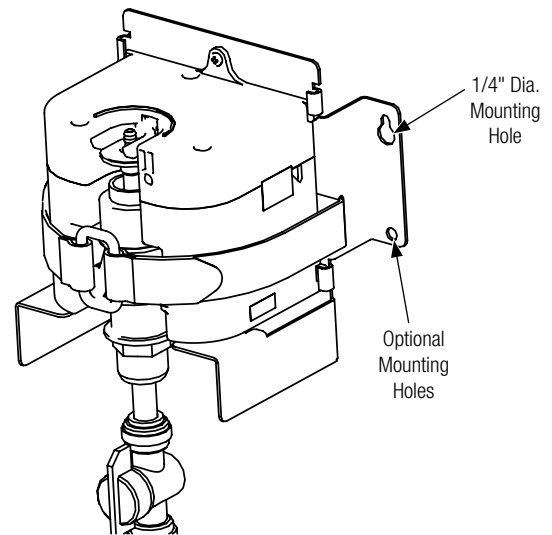

E Position the control box lever under the wings of the soap pump.

6 Top Fill Soap – Control Box & Soap Supply Connections

A Verify the soap pump is positioned below the control box lever.

B Verify the shoulder of the soap pump is positioned above the control box groove.

C Press the soap supply tube over the soap pump connection as shown.

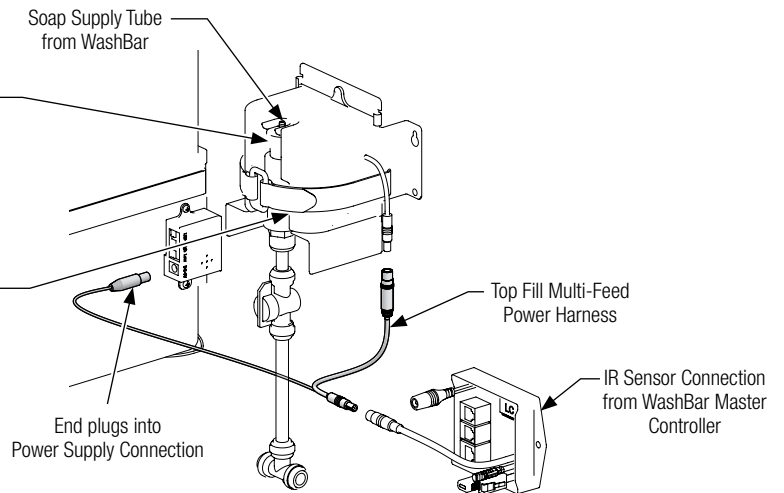

7 Top Fill Soap – Tank Assembly (Part 1)

A Carefully disconnect all connections from the multi-feed tank control box.

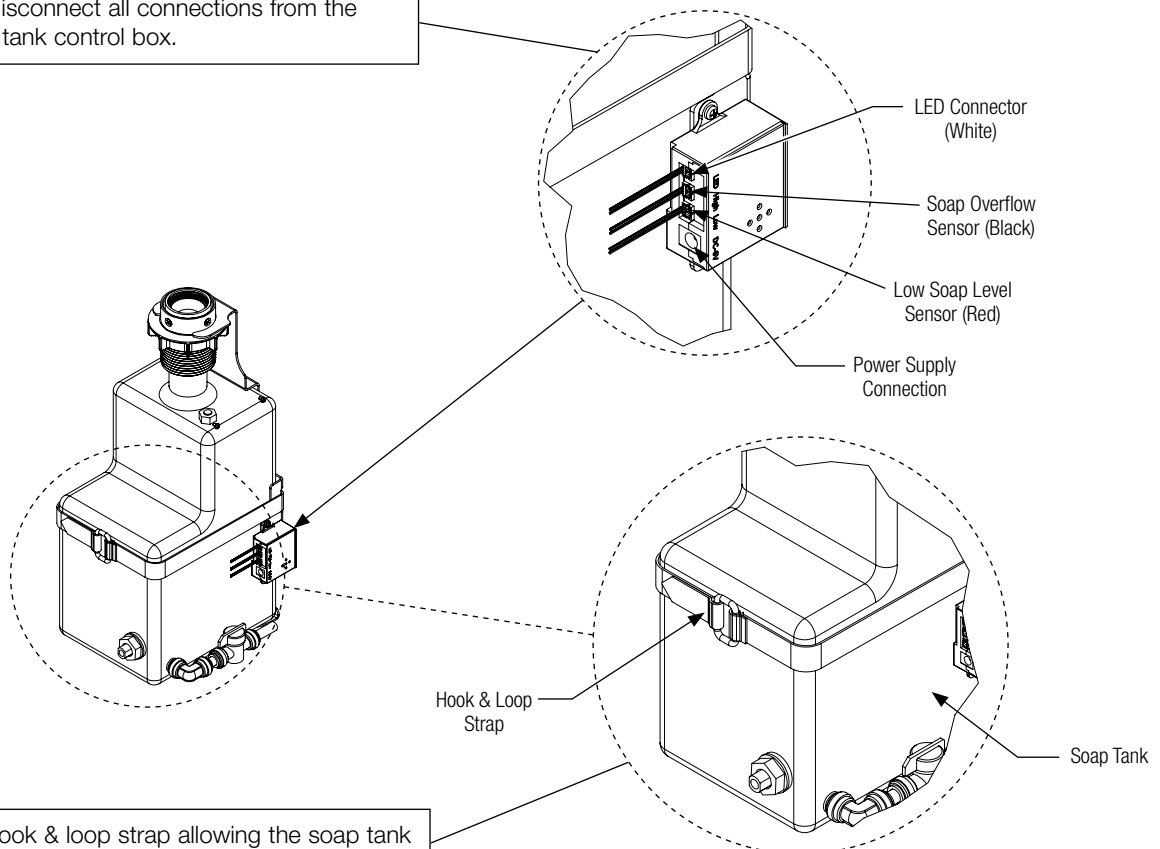

B Remove hook & loop strap allowing the soap tank to be removed from the mounting bracket.

C Carefully remove the fill port hub assembly from the soap tank assembly.



LED and sensor wires are not shown in this view for clarity purposes.

D Remove the mounting nut from the fill port hub assembly.

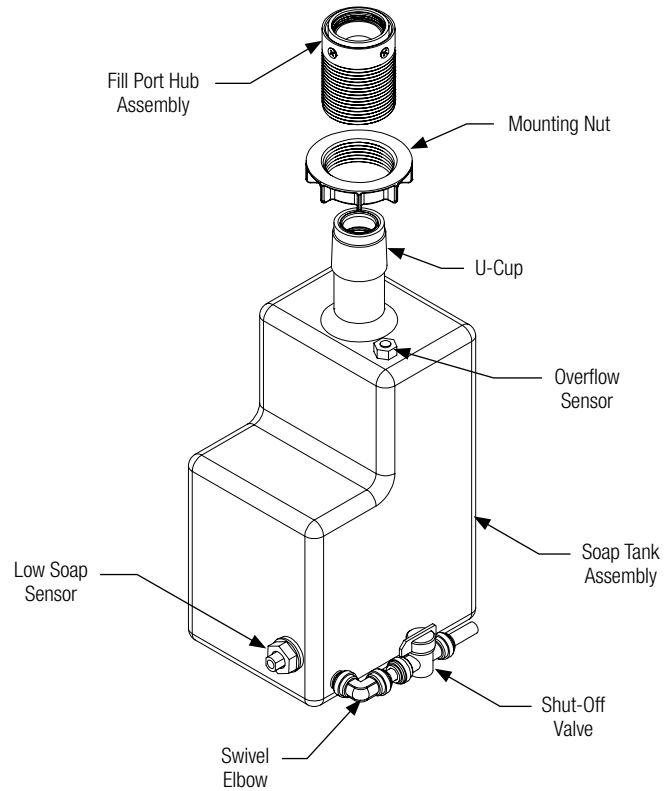

Install Top Fill Components

A With bowl still positioned on the floor, insert the fill port ring into the fill port hub and align the mounting holes. Start the four fill port screws by hand before tightening screws for proper alignment, and then secure in place.

B Insert the fill port cap into the fill port ring. Use the 3 mm Allen wrench (provided with spout assembly) to secure fill port cap in place.

C Using sealant appropriate for quartz or solid surface material when installing the fill port ring is recommended.

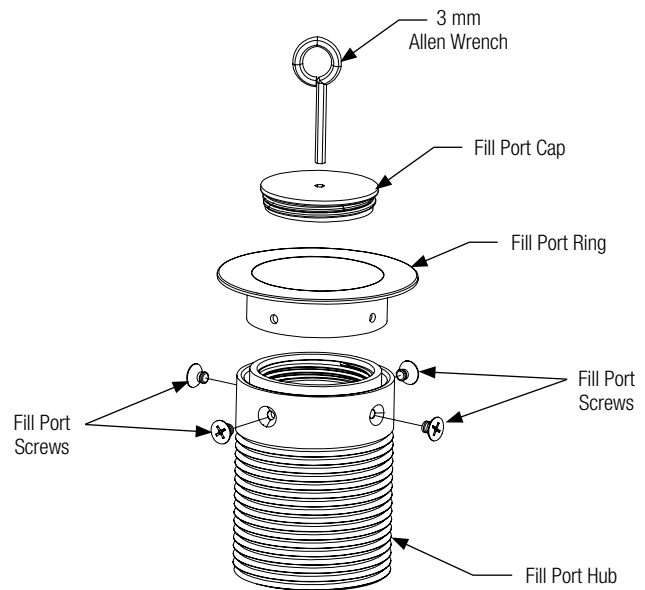

Install Fill Port Hub Assembly on Lav Deck

A Install the fill port assembly through the 2-3/8" diameter hole in the lav deck.

B Position spacer and mounting bracket over fill port assembly and slide upward until spacer is in contact with under side of counter.

C Thread the mounting nut onto the fill port hub assembly. Hand-tighten or torque to 24 in-lb.

The distance between the soap dispenser and the fill port hub assembly can only be a maximum of 42" center to center.

Lavatory deck can only be a maximum of 1-1/2" thick.

Discard spacer when decks are thicker than 1".

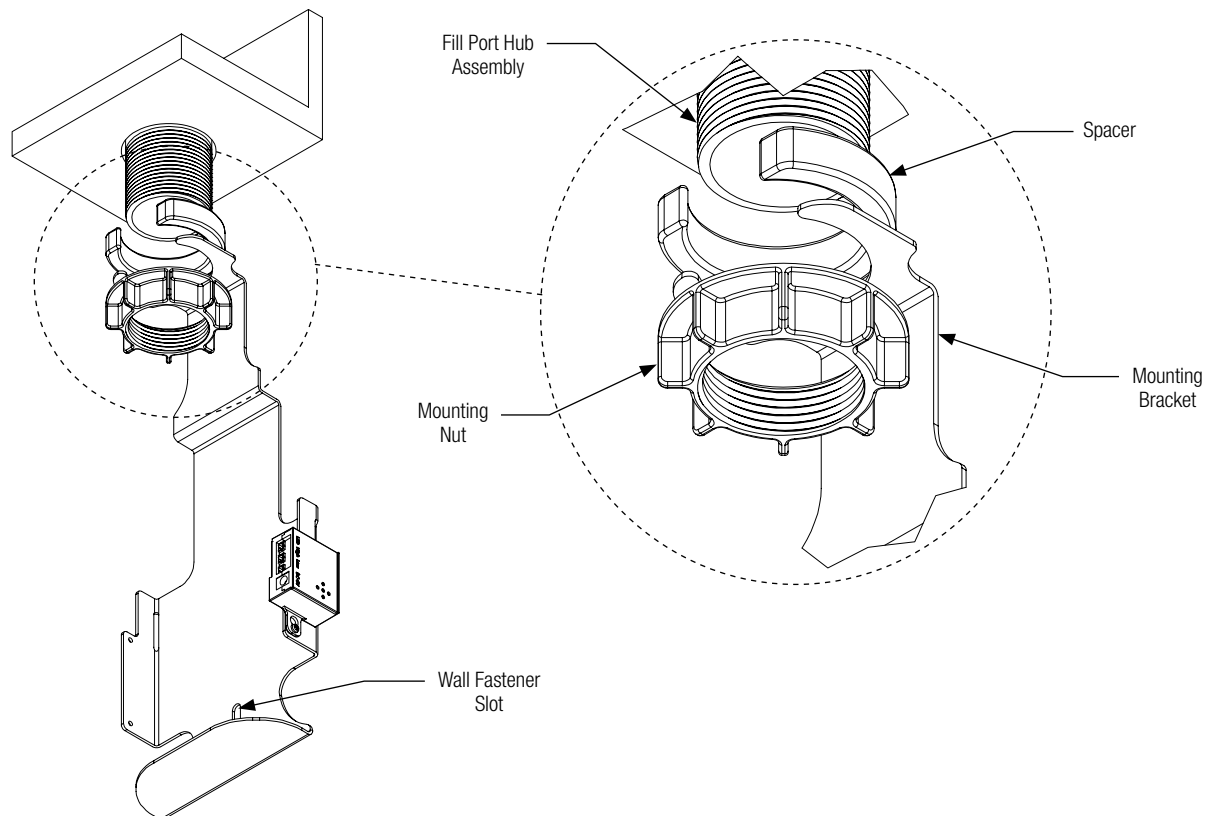

8 Lavatory Mounting to Wall

Mount lavatory to wall following the manufacturer's instructions.

Continue to Step 9 for top fill soap option installation instructions.
 Continue to Step 10 for bottom fill soap option installation instructions.

9 Top Fill Soap – Tank Assembly (Part 2)

Install Soap Tank onto Fill Port Hub Assembly

A Position soap tank in center of fill port hub assembly and slide tank upward until tank is flush with return of mounting bracket.

⚠ CAUTION Keep the LED wire positioned to the side of the fill port hub assembly when inserting the soap tank to prevent the LED wire from getting pinched.

B Place hook and loop strap around soap tank as shown, securing soap tank to mounting bracket.



Scan or click on the code to view a video of how to properly set the U-cup on the tank assembly.

C Visually inspect the installation of U-cup is properly seated, ensuring U-cup does not obstruct fill port opening.



Reinstallation of tank or repositioning of U-cup from above may be needed to clear fill port opening.

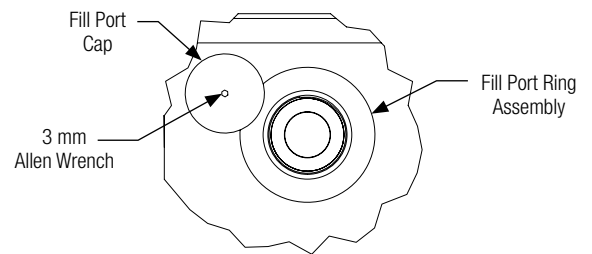
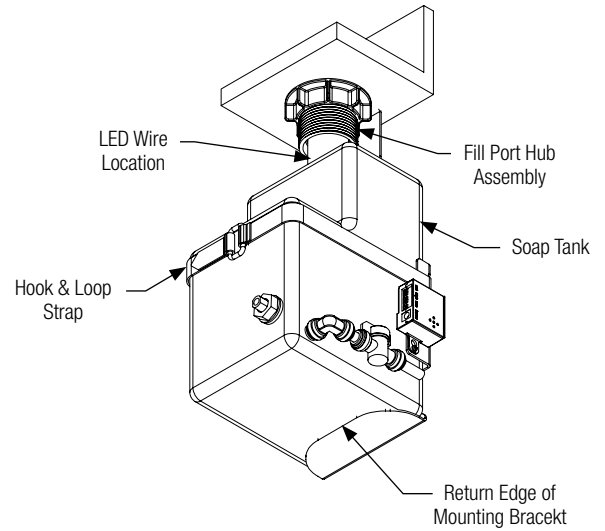

Reconnect Soap Sensors & LED Connector

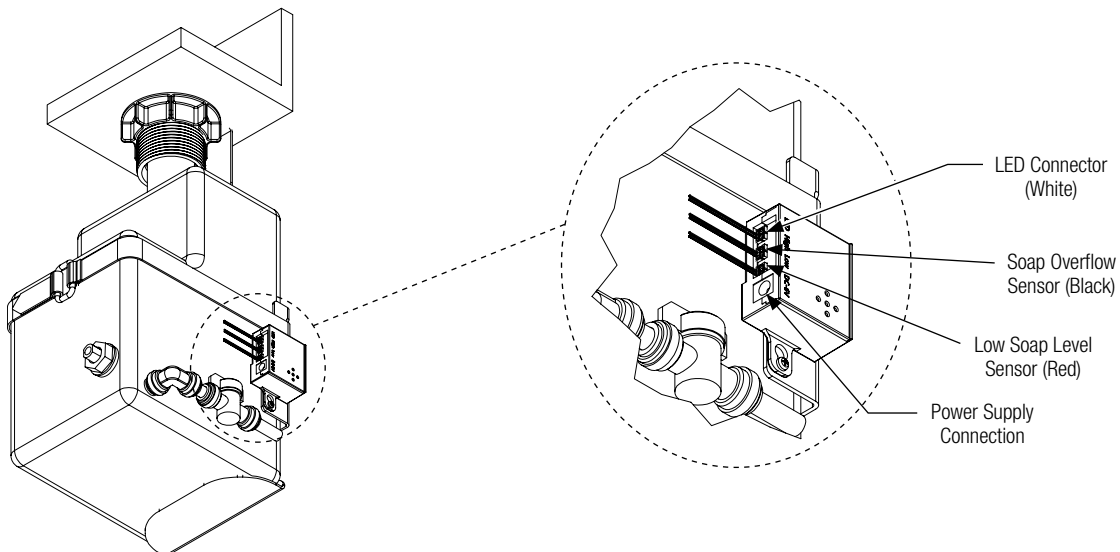

Continue to Step 11.

10 Bottom Fill Soap – Attach Soap Motor & Soap Container Bracket

A Attach soap motor control box and soap container bracket to wall using #10 screws at the locations shown in the Structural Rough-In – Bottom Fill Soap drawing on page 14.

B Attach soap siphon tube to the bottom of the soap pump.

C Install soap pump into the soap control box.

D Secure soap pump to the soap control box using the small hook and loop strap.

E Slide the gallon soap container over the soap siphon tube, and push the soap container up into the soap pump approximately 1/4" (6 mm).

F Clear soap bracket and hold in place against the wall.

The liquid soap pump has a rubber sleeve that fits over the soap container opening. The foam soap pump has an interior white cylinder that fits into the soap container. The fit may be tight. Move the gallon soap container laterally while applying pressure to seat them together approximately 1/4" (6 mm) into soap container opening.

G Slide soap container bracket up until it touches the bottom of gallon soap container. Tighten the #10 screws to secure the soap container bracket to the wall.

H Remove the gallon soap container by swinging it away from the wall and lowering it from the soap syphon tube. Store soap container for later installation.

Continue to Step 11.

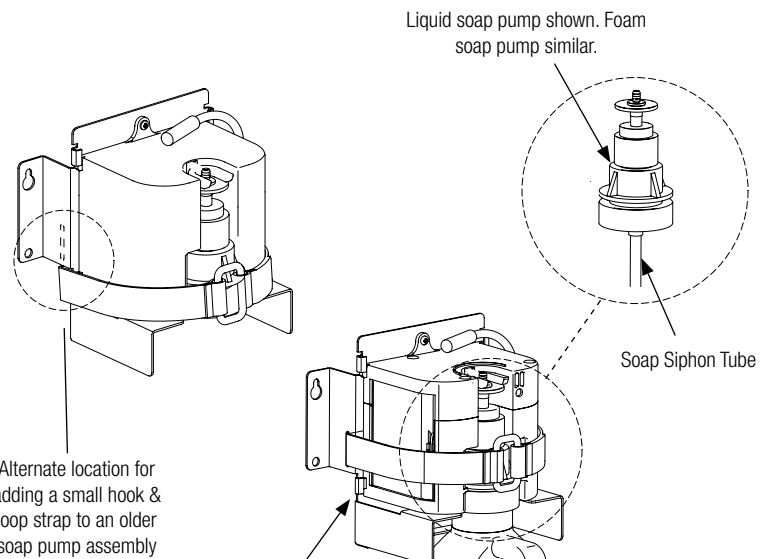
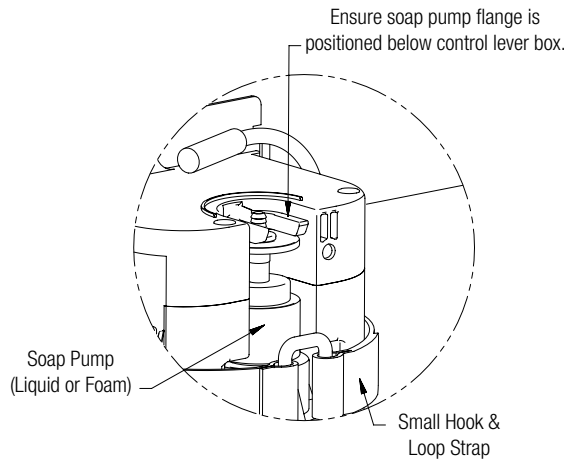

Alternate location for adding a small hook & loop strap to an older soap pump assembly

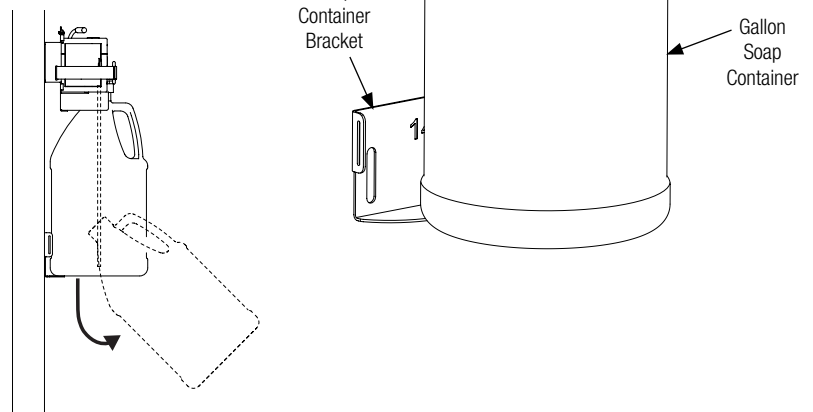

11a Strainer and Standard Drain Cap



1 station shown, 3 station similar.



WashBar removed for clarity.



Drain cap is labeled front and back. Be sure front is facing the user. Top surface of drain cap should be sloped away from user.

A Install the trough strainer and secure in place using the #10 x 1" supplied screws.

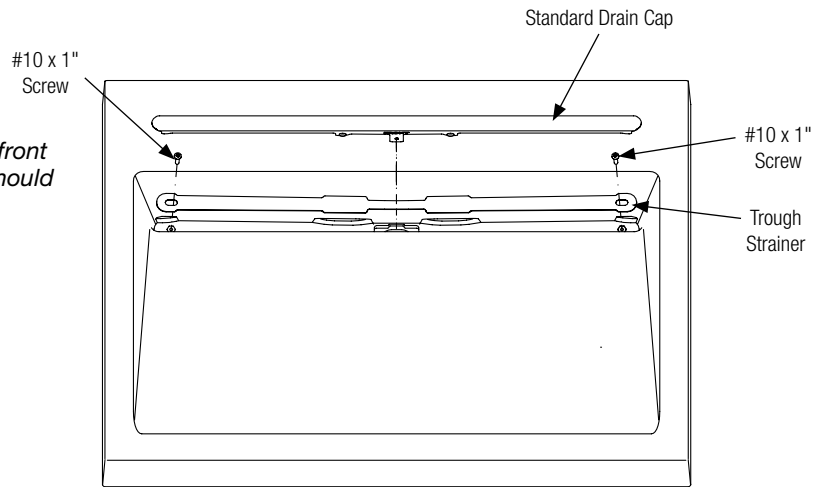

B Position drain cap over trough strainer, aligning tabs into drain. Push drain cap down until drain cap is flush with basin. Grommets should hold drain cap securely against drain trough walls.

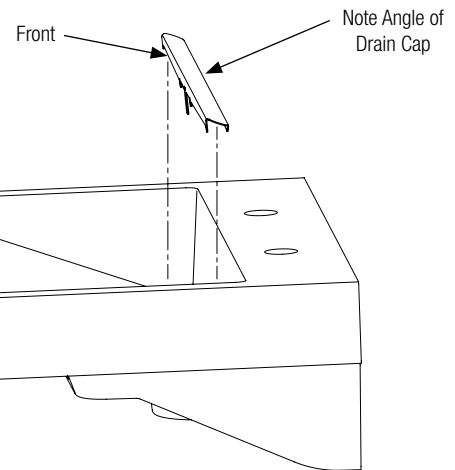

C To remove drain cap, carefully slip flat screwdriver into left or right hand corner of drain cap and gently lift upwards.

11b Strainer and Slotted Drain Cap



WashBar removed for clarity.



Drain cap is labeled front and back. Be sure front is facing the user. Top surface of drain cap should be sloped away from user.

A Install the trough strainer and slotted drain cap as shown. Secure in place using the #10 x 1½" supplied vandal screws.

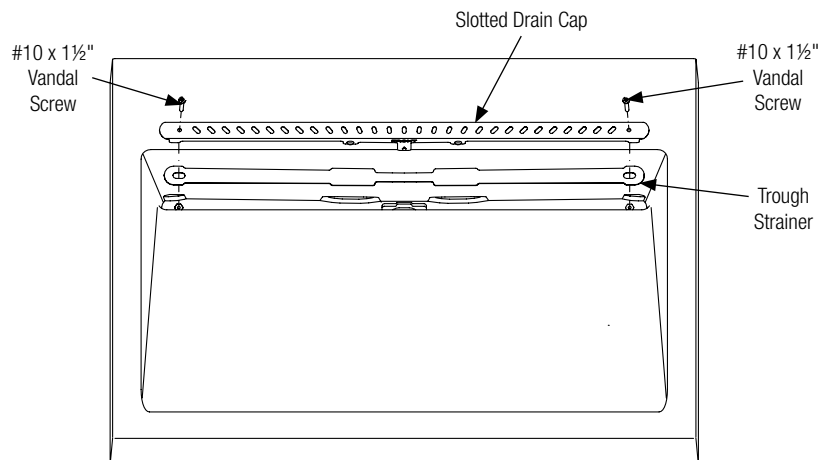

12 Dryer Motor Assembly

⚠ CAUTION If dryer motor is not secured properly to flexible PVC dryer tube, motor may come loose and detach from tube.



WB1 is shown for these instructions.
WB2 is similar.

Slide the hose clamp onto the flexible PVC dryer tube.

A While holding the motor from the bottom, insert dryer outlet nozzle into the flexible PVC dryer tube.

Lightly tighten hose clamp using the 5/16" socket wrench to temporarily hang the blower from the flexible PVC dryer tube.

Push dryer motor to wall and mark installation hole locations.

B Drill marked locations for #8 fasteners appropriate for wall type and construction (supplied by installer).

C Align vibration pad to hole location and stick pad bumper between the dryer motor feet and the wall. Secure dryer and vibration pad to wall with #8 fasteners and #8 washer (supplied by installer).

D Bundle loose cords to motor using hook and loop cable tie.

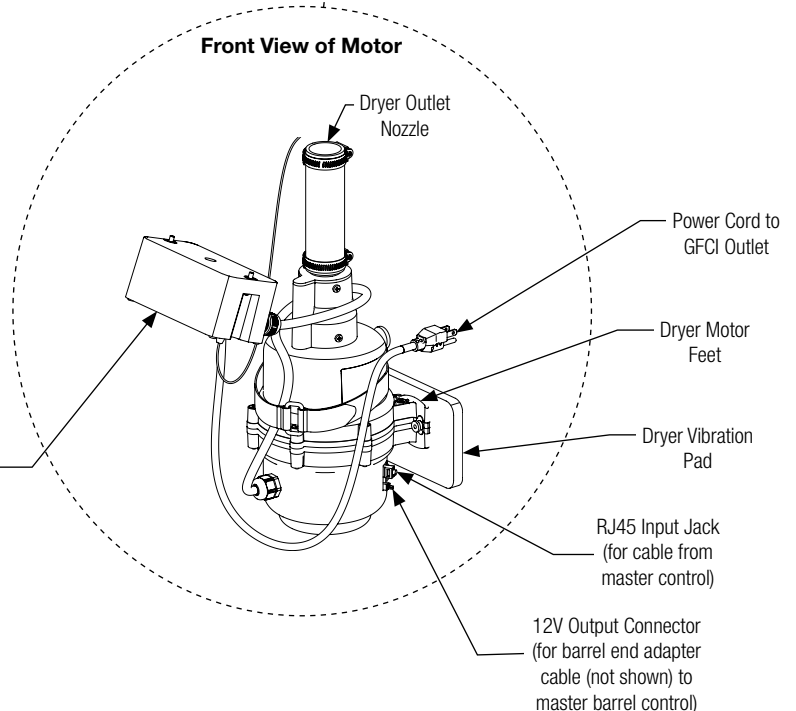
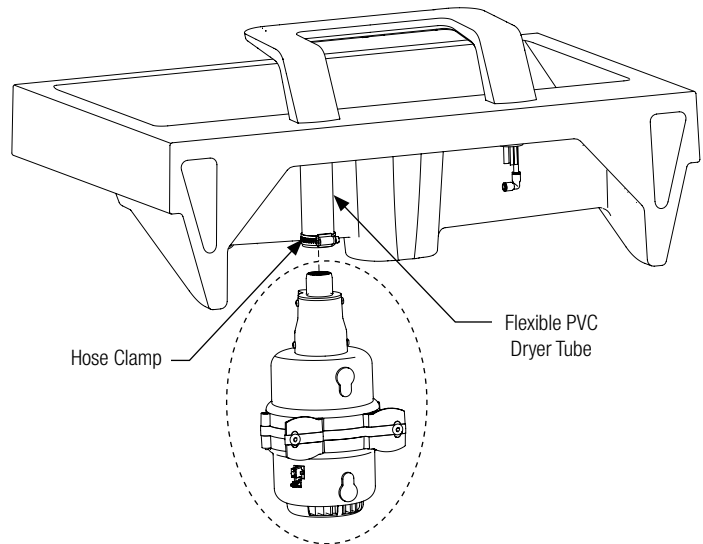

13 Attach Supply Power Enclosure

A Secure supply power enclosure to underside of bowl using (2) #10 x 7/8" screws provided.

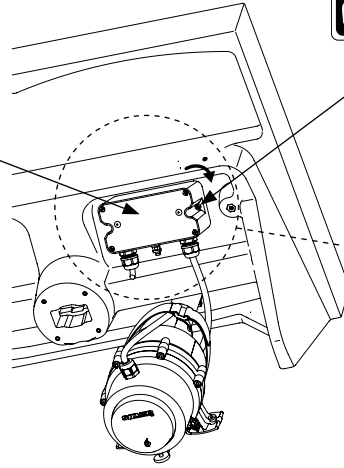

For cam lock option do not install this fastener, then rotate the supply power enclosure slightly toward wall to clear the cam lock bracket. This is only needed on the right cam lock bracket.

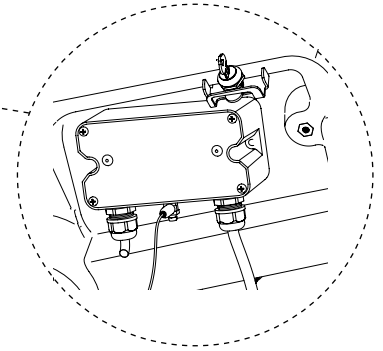

14 Control Box and Valve Installation

A Secure control box to underside of bowl using (2) #10 x $\frac{3}{8}$ " long screws provided.

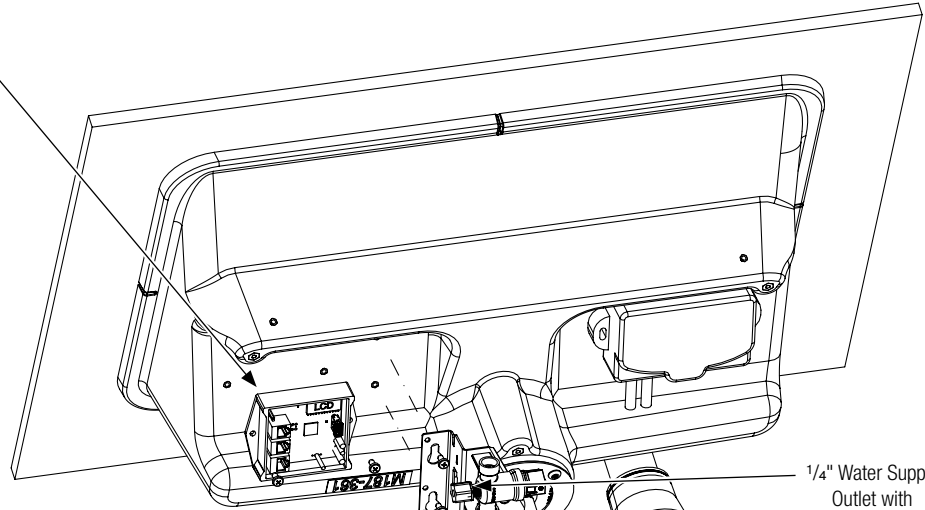

B Secure the valve in place using (2) #10 X $\frac{3}{8}$ " screws provided (see image for assembly).

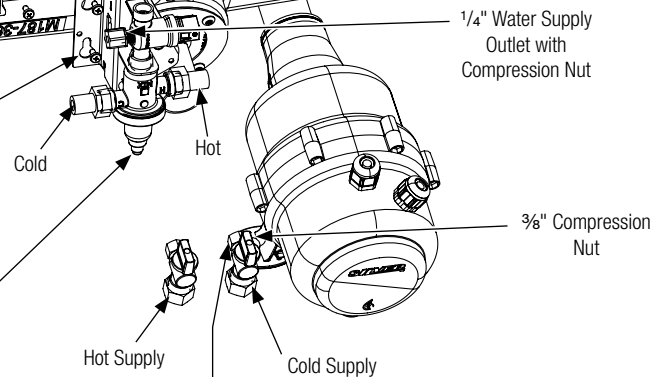

C Attach $\frac{1}{4}$ " supply tube from the WashBar to the $\frac{1}{4}$ " supply valve outlet. Loosen the compression nut on the valve body. Push the $\frac{1}{4}$ " supply tube firmly into the tube connector until it is fully seated. Hand tighten the compression nut.

D Remove $\frac{3}{8}$ " compression nut/sleeve from the hot and cold supply stop valves. Connect $\frac{3}{8}$ " end of flexible supply hose to $\frac{3}{8}$ " compression on supply stop valve. Ensure hot and cold supply hoses are connected to hot and cold supply stop valve.

For the TL option, only connect tempered supply.



Continue to Step 15 for top fill soap option installation instructions.

Continue to Step 16 for bottom fill soap option installation instructions.

15 Top Fill Soap – Soap Installation

Soap Supply Connections



See page 32 for an overview of the end tank configuration installation.

A Insert 3/8" diameter tubing into the elbow as shown. Connect the supply tube to the nearest control box, cutting the supply tube to the shortest length between units.



Tubing will slide 3/4" into the fittings.

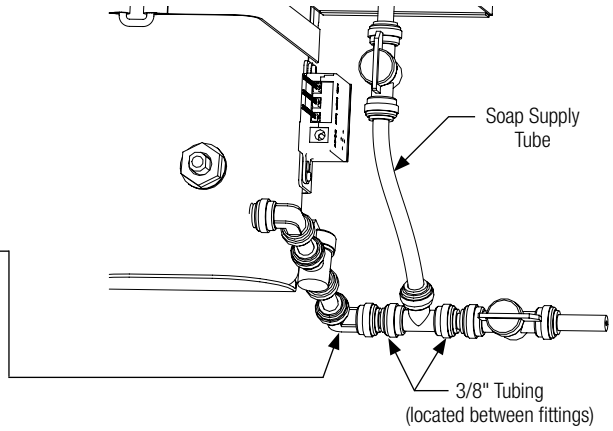

B Cut one piece of tubing 3–4" in length and assemble as shown.

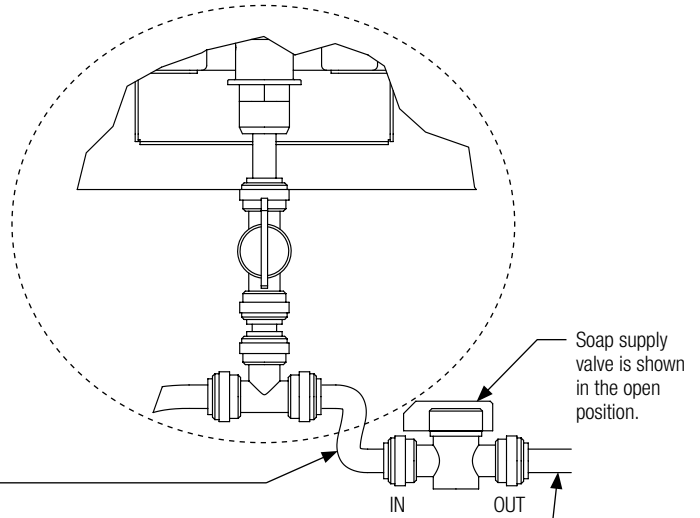

C Install extra tubing after the shut off valve (located at the end of the soap supply system).



Install the soap supply valve in the proper flow direction as shown on the valve.



Use the extra tubing when cleaning and/or maintaining the soap system.

1-Person Soap Tubing Layout



Single WB-TR1 or WB-ER1 bowl is shown. Other multiple bowl configurations are similar.

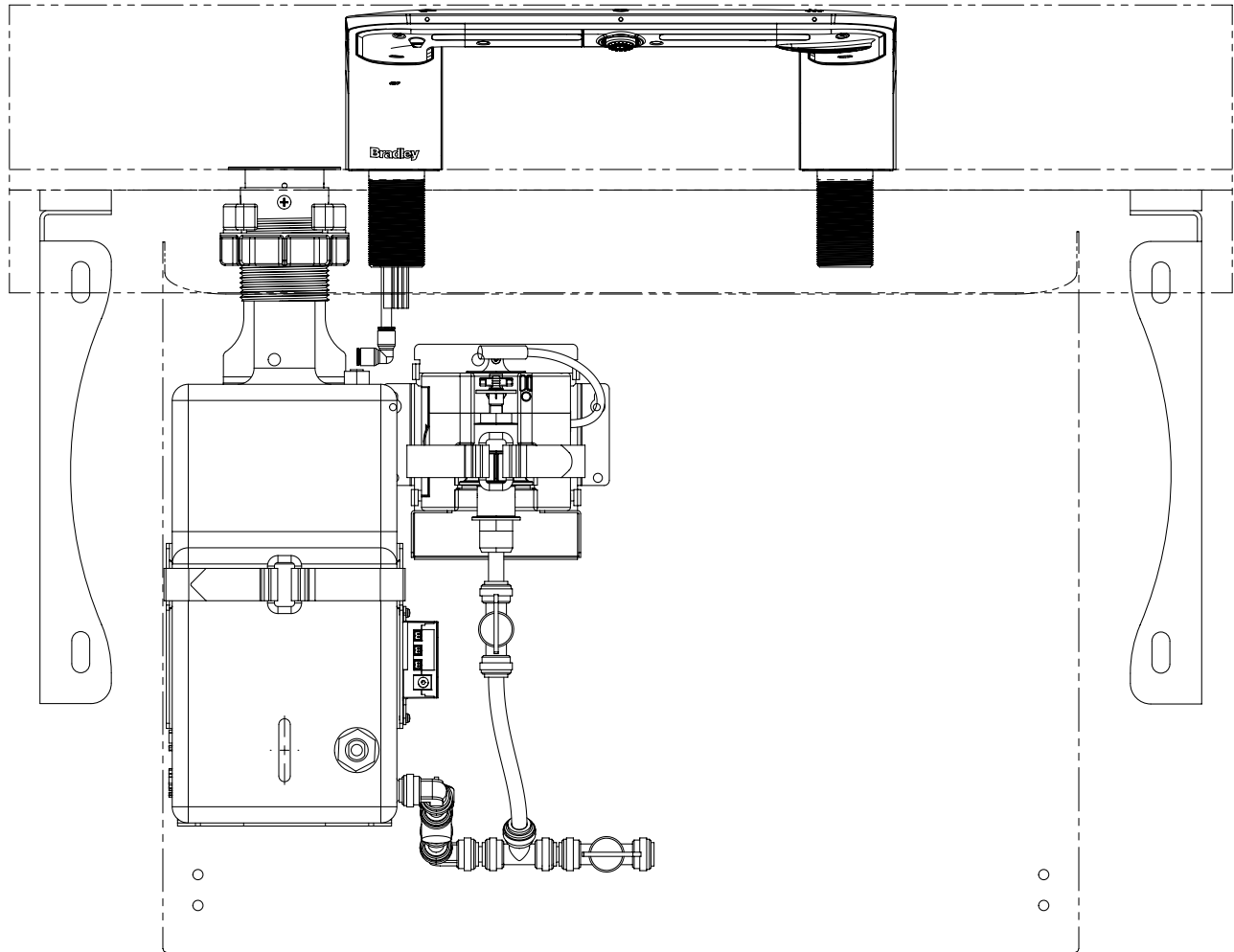

Add Soap to Top Fill Soap Tank Assembly

- When the soap level is at approximately 25% capacity, the LED indicator on the fill port hub assembly will flash red, indicating low soap levels.

Soap tank capacity is 166.5 oz (5026 mL).

- A** Remove the fill port cap from the fill port hub assembly using the supplied 3 mm Allen wrench. Set the fill port cap aside.

- B** Slowly pour the soap into the fill port hub assembly.

- To prevent overfilling, the LED indicator on the fill port hub assembly will turn solid red and an audible indicator will sound for 2.5 seconds, indicating that soap levels are at 90% capacity.

- C** Replace the fill port cap into the fill port hub assembly and hand-tighten.

- Initial installation requires multiple activations to prime each soap spout dispenser.

- If top fill soap is included, be sure to download the latest software revision in order to disable the cycle count on the WashBar. Refer to the Software Update section on page 43.

- Continue to Step 17.**

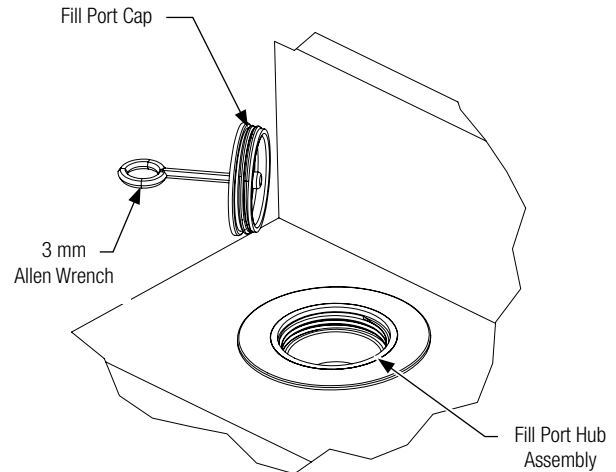

16 Bottom Fill Soap – Soap Installation

✓ The soap system is designed to be used with a standard U.S. gallon soap container. For accurate low soap indication, user needs to set soap type (see Configuration Mode on page 41 to set soap type).

✓ Soap cycle count defaults to liquid soap configuration. If you have the foam soap option, please see Setting the Soap Type under Configuration Mode on page 41.

A Slide gallon soap container over soap siphon tube and into the soap pump as shown.

✓ The liquid soap pump has a rubber sleeve that fits over the soap container opening. The foam soap pump has an interior white cylinder that fits into the soap container. The fit may be tight. Move the soap pump laterally while applying pressure to seat into soap container opening.

B Set gallon soap container onto lower soap tank bracket and hold in place.

C Use the provided hook and loop strap to secure container to the soap bracket. Feed the end of the strap (smooth side facing you) through the left side slot of the bracket flange at top. Feed through right side flange slot and wrap around jug. Secure with the hook and loop end.

✓ The hook and loop strap can be slid within bracket so buckle is closer to the left side of bracket. This makes the strap easier to use on smaller tanks.

D Attach soap supply tube from the WashBar to the top of the soap pump.

E Ensure that the soap tube is not kinked. Position hand above soap motor control box and adjust tube if needed.

F To manually prime the soap, press the soap pump flange 6 to 8 times.

✓ For ease of soap container removal, swing it away from the wall to clear the soap container bracket and lower it to clear the soap siphon tube.

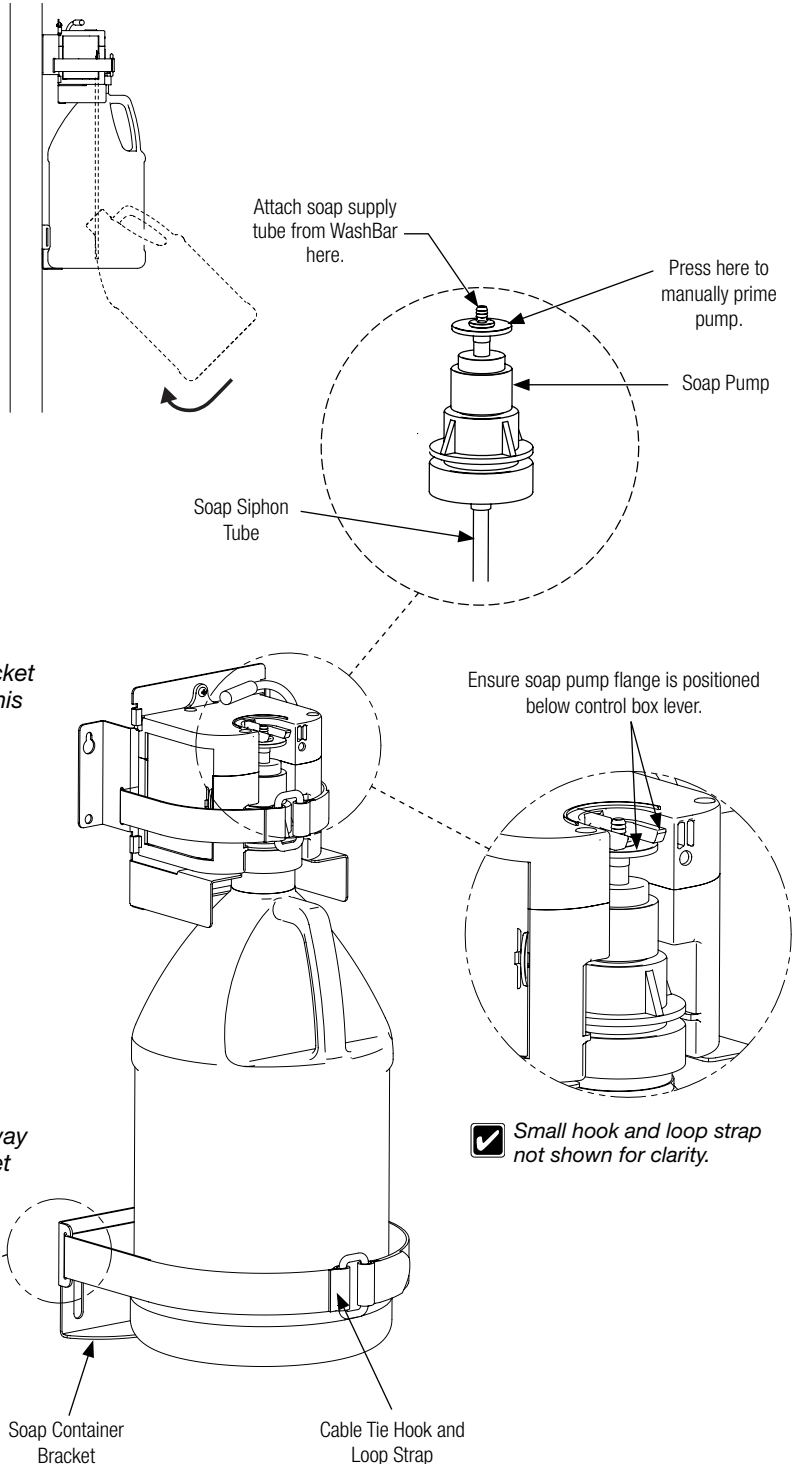

Top Flange

Cable Tie Slot

Soap Container Bracket

Cable Tie Hook and Loop Strap

✓ Small hook and loop strap not shown for clarity.

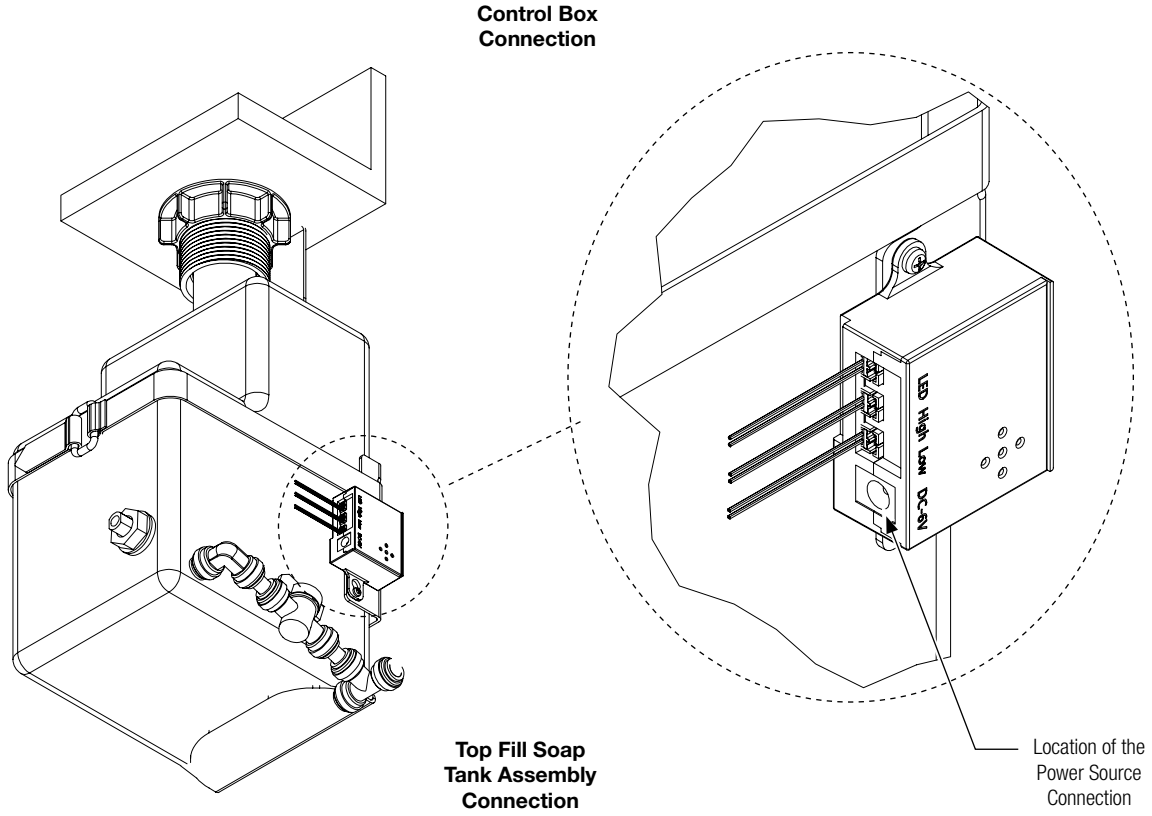

17 Electrical Connections – Brushless Motors (July 2023-present)



Each WashBar requires the same connections.

B Connect the 12V supply cord male barrel plug into the master control female barrel plug. Plug the 12V supply cord into the 12V output connector.

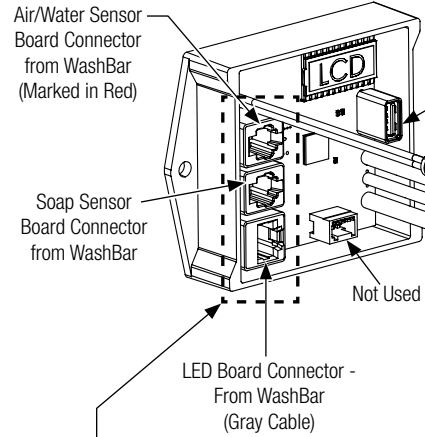

A Make (3) connections from the WashBar assembly as shown (Air/Water Sensor, Soap Sensor, and LED)

D Use the cable tie hook and loop strap to secure all electrical cords in place.

E After all connections are made, reference Master Control Box: System Startup section later in this manual.

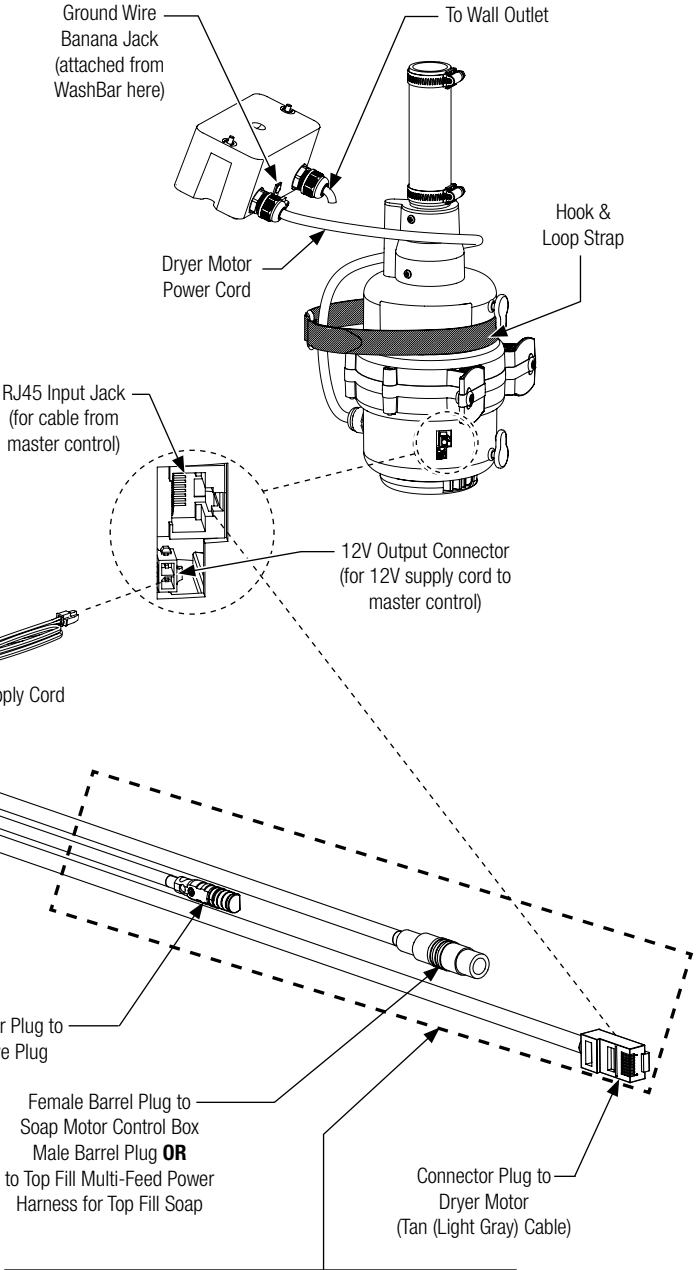

C Make (3) connections to the DC valve plug, the soap motor control box, and the dryer motor.

Electrical Connections – Brushless Motors (cont.)

F Attach push connector to grounding wire washer (installed between the deck and large WashBar nut). Loosen grounding lug screw and attach banana plug end of the grounding wire washer into the grounding lug on the supply power enclosure. Tighten screw to secure banana plug.

CAUTION Use of a grounding strap is required. Warranty may be void if grounding strap is not properly installed.

G Plug dryer power cord from dryer motor into GFCI (RCD) protected wall outlet. Keep the area clear under WashBar until the LEDs light up blue. Wait 5 seconds. Place hands under soap dispenser, water, and dryer to be sure all functions work properly. Check for water leaks.

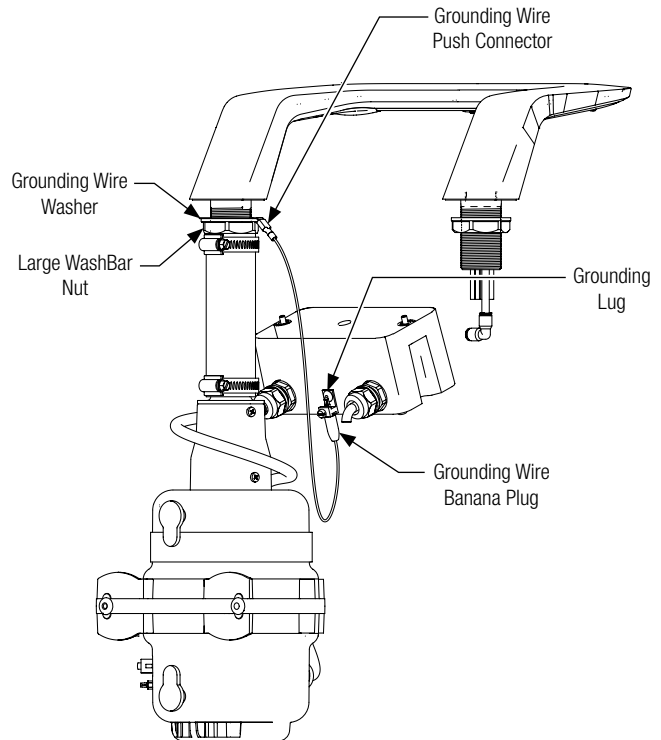
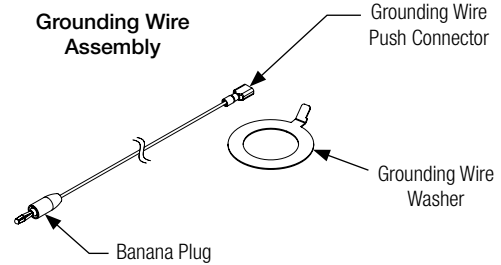

18 Adjust Temperature with Water Running

WARNING This valve is NOT factory preset. Upon installation, the temperature of this valve must be checked and adjusted to ensure delivery of a safe water temperature. Water in excess of 110°F (43°C) may cause scalding.

A Loosen cap screw about 1/4" (4–6 turns) and lift up cover (do not remove).

B Using cover, turn cartridge gently until desired water temperature is reached. Do not turn past stops as this may damage unit. Push cover down and tighten screw.

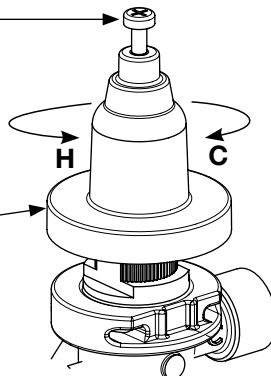

19 Access Panel

⚠ CAUTION For applications where children are present or for applications subject to vandalism, order security screw option S45-2880.



Make all connections before installing access panel.



Thumb screw installation is shown. Similar installation for vandal-resistant screws. For cam locks, refer to the separate installation guide provided.



For ease of installation, lift trap cover up at bottom, while positioning over thumb screw. Start at center and move left to right.

A

Use the supplied split cable sleeve to route loose wires and cables. Be sure to leave room so the soap container can be easily accessed for maintenance and refilling.

B

Attach the access panel brackets to the wall (refer to rough-in drawing) by installing the #10 top screws (supplied by installer) into the slotted holes. **Do not install the #10 bottom screws at this time.**

C

Insert #10 thumb screws into front bowl apron. Thumb screw in vertical position is closed. Thumb screw in horizontal position is open.

D

Hang access panel onto the mounting brackets attached to wall on the left and right sides. Rotate panel up and check fitup between thumb screws and panel slots. Rotate the access panel down and adjust the access panel brackets if necessary.

E

After access panel brackets are properly adjusted, install the #10 bottom screws to secure the brackets in place.

F

Attach P-trap to drain adapter and waste outlet.

G

Plug the grounding wire assembly adapter from WashBar to wall outlet.

H

Plug dryer power cord from dryer motor into GFCI protected wall outlet. Keep the area clear under WashBar until the LEDs light up blue. Wait 5 seconds. Place hands under soap dispenser, water, and dryer to be sure all functions work properly. Check for water leaks.

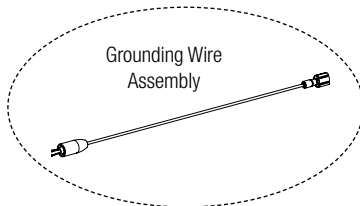
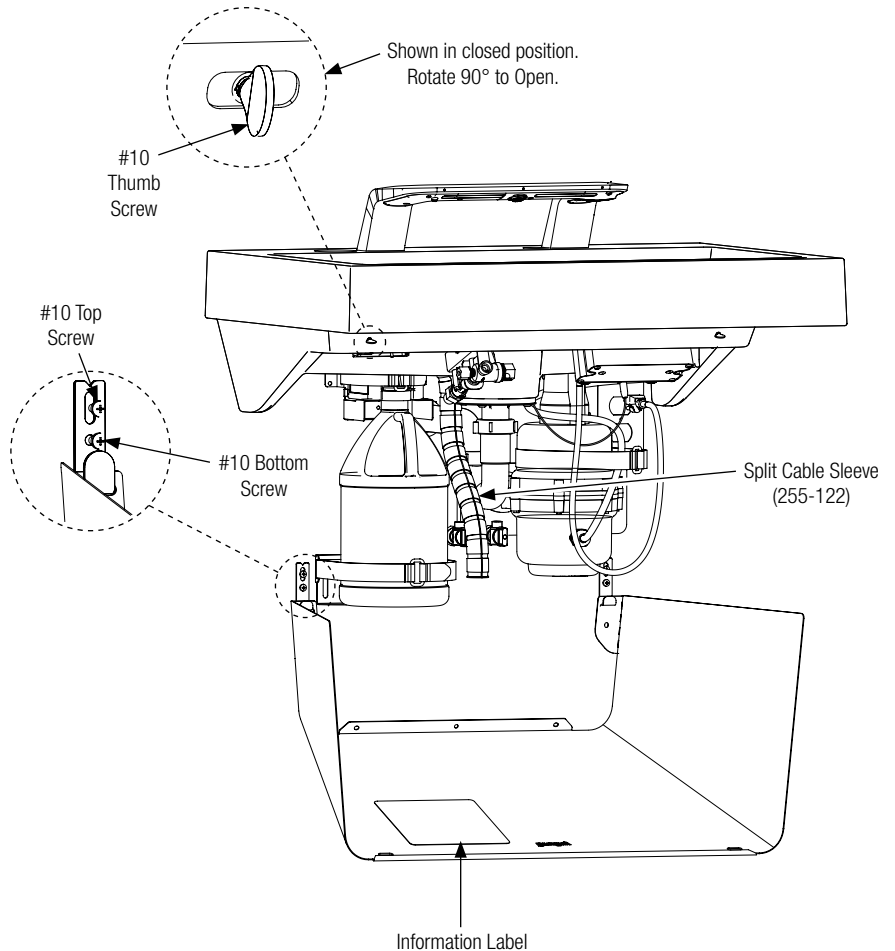

I Rotate access panel up and secure by rotating thumb screws to the closed position.

J

To open access panel, rotate thumb screw, slightly push panel up and swing access panel down. Do not remove thumb screws.

Master Control Box



Scan to watch maintenance and troubleshooting videos for the WashBar!

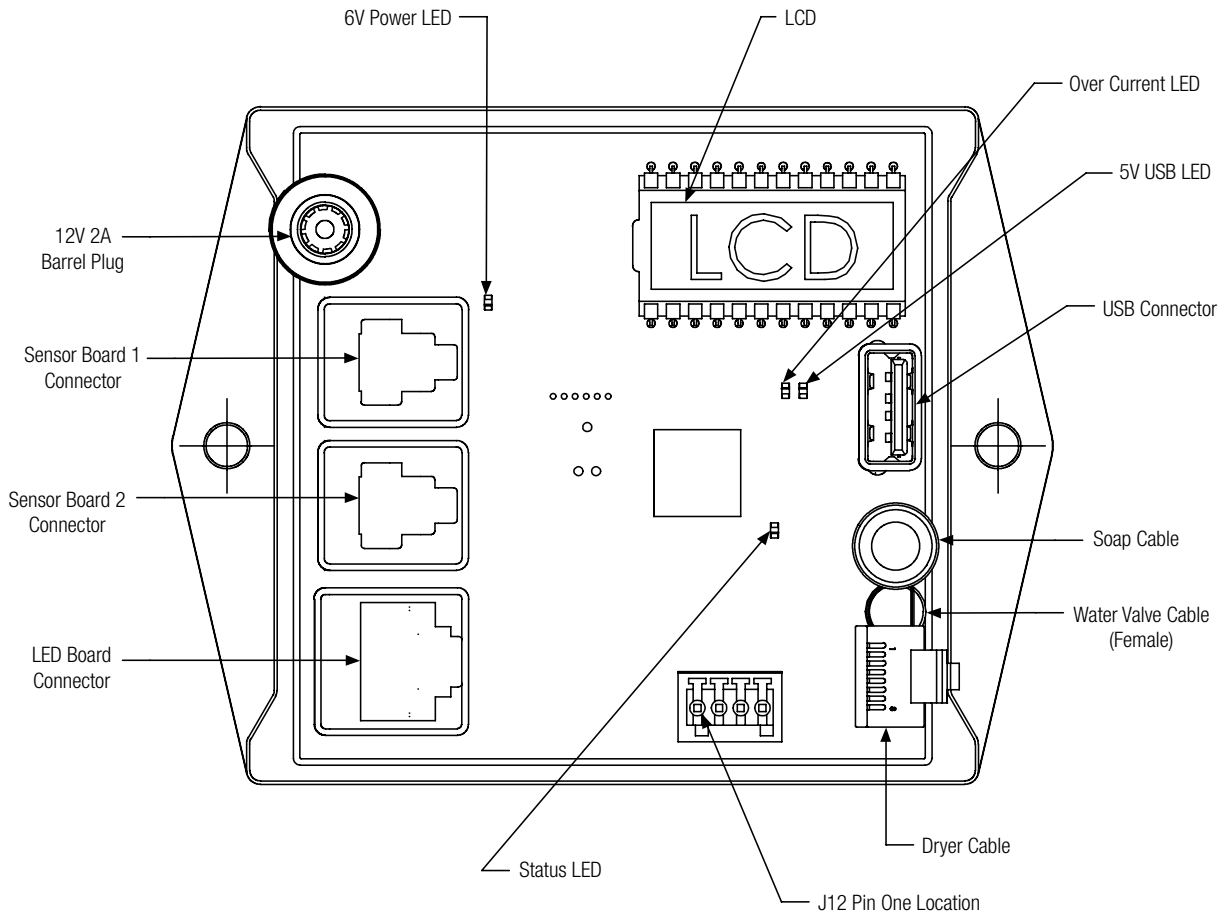

System Startup



Before powering on the WashBar, ensure that the area beneath it is free of any obstructions and the sensors are clear. When power is first supplied, the blower may briefly activate if it is present.

The first time the WashBar is powered up, there is a sequence of LEDs that will light up.

- Within 5-10 seconds of receiving power, the WashBar will cycle its LED lights RED, GREEN, and then BLUE. When the LEDs turn blue, the WashBar is in Standby/Idle Mode.



If any of the WashBar LEDs flash RED, check for sensor obstruction. After obstruction is removed or cleaned, the WashBar LEDs will return to blue indicating that the WashBar is in Standby/Idle Mode.

- The power LED on the master control box will be GREEN indicating the unit has power.

Master Control Box: Operation Modes

Standby/Idle Mode

Standby/Idle Mode is automatically activated when the WashBar is not in use. All of the sensors (soap, water, dryer) are active in this mode. When any sensor is activated (soap, water, dryer or approach), the WashBar will exit Standby/Idle Mode.



The dryer has a 1.5 second delay in this mode.

LED Indicators	Meaning
All blue dimmed	Default/normal
All blue	User option, See Configuration Mode
All off	User option, See Configuration Mode
Only soap LED solid red	Low soap (Reset: Hold hand under soap sensor until red LED turns off, approximately 13 seconds.)
Soap and water LED solid red	Soap sensor board error
Air and water LED solid red	Air sensor board error
Soap and air LED solid red	Both sensor boards error
All LED solid red	Air sensor board error and low soap
Any flashing red LED	Dryer, water, or soap has timed-out. This is caused by an obstructed sensor. Remove obstruction or wipe sensors with microfiber cloth to prevent from scratching sensor. System will return operational automatically once cleared.

Operation Mode

Operation Mode is the normal dispensing/washing/drying mode automatically activated when the WashBar is in use. All of the sensors (soap, water, dryer) are active in this mode.

While in Operation Mode:

- The soap and water can activate at the same time but the dryer cannot activate at the same time as the soap and water.
- When dryer is active, disable water sensor closest to dryer.
- When a water sensor is still detecting an object after 30 seconds, the water will shut off and wait for a no-detect before becoming ready again.
- To reset low soap, hold hand under soap for 13 seconds (see table below for low soap indicator LED).
- When a soap sensor is still detecting an object after 15 seconds, the soap will prime for 30 seconds or until a no-detect occurs before becoming ready again.
- When a dryer sensor is still detecting an object after 30 seconds, the dryer will shut off and wait for no detect before becoming ready again.

LED Indicators	Meaning	Solution
All blue bright	Ready Mode	n/a
Green bright	Dispensing soap, water, or air	n/a
Only soap LED solid red	Low soap (Reset: Hold hand under soap sensor until red LED turns off, approximately 13 seconds)	Refill soap.
Soap and water LED solid red	Soap sensor board error	Contact Bradley Technical Services.
Air and water LED solid red	Air sensor board error	Contact Bradley Technical Services.
Soap and air LED solid red	Both sensor boards error	Contact Bradley Technical Services.
All LED solid red	Air sensor board error and low soap	Contact Bradley Technical Services.
Any flashing red LED	Dryer, water, or soap has timed-out. This is caused by a obstructed sensor.	Remove obstruction or wipe sensors with microfiber cloth to prevent from scratching sensor. System will return operational automatically once cleared.

Cleaning Mode

Cleaning Mode temporarily locks out the WashBar for approximately 30 seconds. All of the sensors (soap, water, dryer) are inactive in this mode. After 30 seconds, the WashBar will exit Cleaning Mode and return to Standby/Idle Mode. Use a soft cloth and ethyl alcohol or water to clean WashBar access plates/sensor windows.

To activate Cleaning Mode:

1. Place a hand under the dryer and then immediately (within 1 second) under the soap sensor and hold hands under both dryer and soap sensors for approximately 5 seconds until all LED lights turn solid white.
2. Remove hands only when all LED lights turn solid white.



LED lights may flash and cycle different colors. To activate this mode, only remove hands once all LED lights are solid white.

Configuration Mode

Configuration Mode is when the user can configure the WashBar or obtain cycle counts for soap, water and dryer. All of the sensors (soap, water, dryer) are active in this mode. After 10 seconds of no use, the WashBar will slow flash all LEDs green and then return to Standby/Idle Mode.

To activate Configuration Mode:

1. Place a hand under the dryer and then immediately (within 1 second) under the soap sensor and hold hands under both dryer and soap sensors for approximately 10 seconds until all LED lights turn solid red.
2. Remove hands only when all LED lights turn solid red.



LED lights may flash and cycle different colors. To activate this mode, only remove hands once all LED lights are solid red.



While in Configuration Mode, LED lights will be solid red unless changing configurations or getting cycle counts.

Cycle Counts

To display cycle counts, while in Configuration Mode:

1. Place and remove hand within 3 seconds under the device you want to get a cycle count for (soap, water, dryer).
2. The LED light for that device will turn green to indicate the count will follow.
3. The LED light for that device will turn solid red and then flash the number of cycles as follows:
 - Soap: the LED flashes the number of 100,000 cycles for the device.
 - Water: the LED flashes the number of 10,000 cycles for the device.
 - Dryer: the LED flashes the number of 1,000 cycles for the device.

For example, a water activation cycle of 248,000 will be displayed in the following order: A solid green water LED, followed by a 1.5 second solid red soap LED, followed by 2 white soap LED flashes (indicating the 2 in 248,000). Next, there will be a 1.5 second solid red water LED followed by 4 white soap LED flashes (indicating the 4 in 248,000). Finally, a 1.5 second solid red dryer LED followed by 8 white soap LED flashes (indicating the 8 in 248,000).

Setting the Soap Type

If the WashBar is set to the correct soap type, the low soap indicator will display low soap at 80% empty as intended. If not set correctly, a liquid soap system will be empty before indicator lights up if set to foam and a foam soap system will be 60% empty if set to liquid.

To set soap type, while in Configuration Mode:

1. Hold hand under soap sensor for 5 seconds to start selection process. Selection options will cycle until hand is removed.
2. Continue to hold hand under soap until desired setting color is shown then remove hand while color is being displayed.
 - Red LED: Liquid Soap (3200 dispensing cycles occur before low soap counter needs to be reset. This is the Default setting when WashBar is reset.)
 - Blue LED: Foam Soap (4000 dispensing cycles occur before low soap counter needs to be reset.)
 - LED Off: Disables low soap counter (may not be available for all models).
 - No LED: WashBar with Top Fill Soap (Low soap indicator is disabled. WashBar will ignore soap counter and low soap indicator will not show LED status on WashBar.)

Setting the LED Lights ON (Bright) / ON (Low) / OFF for Standby/Idle Mode

To set the LED lights to ON (Bright) / ON (Low) / OFF for Standby/Idle Mode, while in Configuration Mode:

1. Hold hand under water sensor for 5 seconds to start the selection process. Selection options will cycle until hand is removed.
2. Continue to hold hand under water until desired setting color is shown then remove hand while color is being displayed.
 - Blue LED (Bright): standby LEDs ON (default when WashBar is reset)
 - Blue LED (Low): Standby LEDs slightly dimmer
 - LED Off: standby LEDs OFF

Setting Motor Speed

To set the dryer motor speed, while in Configuration Mode:

1. Hold hand under dryer for 5 seconds to start selection process. Selection options will cycle until hand is removed.
2. Continue to hold hand under dryer until desired setting color is shown then remove hand while color is being displayed.
 - Red LED: High Speed (default when WashBar is reset)
 - Blue LED: Medium Speed

Reset Mode

Reset Mode is when the user can reset all WashBar settings back to their default settings. This removes all custom configuration options but does not reset counters. Counters cannot be reset. All of the sensors (soap, water, dryer) are active in this mode. Once the WashBar has been reset, it will automatically return to Standby/Idle Mode.

To reset the WashBar:

1. Place a hand under the dryer and then immediately (within 1 second) under the soap sensor and hold hands under both dryer and soap sensors for approximately 20 seconds until all LED lights turn solid green.
2. Remove hands once all LED lights turn solid green. WashBar has now been reset and will return to Standby/Idle Mode. If foam soap is being used, the soap type will need to be set to foam. If this step is not done, the low soap indicator will not be accurate. See Configuration section "Setting the Soap Type."



LED lights may flash and cycle different colors. To reset the WashBar, only remove hands once all LED lights are solid green.

24 Hour Water Purge

If water has not been used within 24 hours, the WashBar will automatically run water for 5 seconds. This is not configurable by the user.

Software Update



Software revisions can be found at www.bradleycorp.com/software-updates/washbar.

The master control board software can be updated using a USB flash drive. To update the software:

1. Download the desired software revision into the ROOT directory of a USB flash drive (do not copy file in any folder).
2. Place the USB flash drive containing the desired software into the master control board. Disconnect the barrel plug to power off. Then reconnect the barrel plug. Wait a few seconds for the control box to restart.
3. DO NOT REMOVE FLASH DRIVE until status LED on master control board turns off and LED lights on WashBar turn all BLUE to indicate update is complete.



LEDs may turn off after ALL have flashed BLUE if standby LED setting is set to "OFF". RED LEDs may be solid if low soap or board error has occurred or Flashing RED if sensor is blocked.

4. Remove USB flash drive if desired. Leaving USB flash drive in master control board will not affect WashBar performance.



Software version will display on the LCD screen. Software can be reversed to a previous version by having only an earlier version of the software on the USB flash drive.

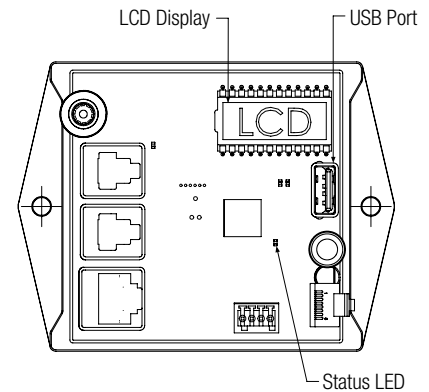

Displaying Software Revision and Cycle Counts on LCD Display

The master control board has an LCD screen that continuously displays information about the software version and cycle counts for the soap, water and dryer. To view the LCD display:

1. Open the access panel.
2. Locate the LCD screen on the master control board. The display will cycle through the software revision and counts. Cycle counts are displayed x1000 (ex. 65 = 65,000)
 - REV followed by the software revision
 - SOP followed by the soap cycle count
 - H2O followed by the water cycle count
 - AIR followed by the dryer cycle count

Cleaning and Maintenance for Terreon®

Material Description: Terreon is a densified solid surface material composed of bio based resin and is resistant to chemicals, stains, burns and impact. Surface can be easily repaired with everyday cleansers or fine grit abrasives. Because Terreon is a unique cast material, its aggregate flow and distribution, and shades of color can vary from product to product creating natural characteristics.

Routine Cleaning: For regular cleaning, use mild neutral base cleaners.

Stubborn Stains: Remove tough stains with Soft-Scrub® and a green Scotch-Brite® pad or lightly sand in a circular motion with 240 grit wet/dry sandpaper. The finish can then be renewed with a maroon Scotch-Brite pad.

Scratches: Remove scratches with a green Scotch-Brite pad. The finish can then be renewed with a maroon Scotch-Brite pad.

Hard Water Deposits: Remove hard water deposits with a mild solution of vinegar and water. Always rinse the unit thoroughly after cleaning.

Restoring the surface: Use Hope's® Perfect Countertop to refresh and protect the Terreon Solid Surface material. Dark Terreon colors may require additional care and maintenance. For complete instructions on this additional maintenance, visit bradleycorp.com.

Repair Kits: Terreon repair kits are available. Contact your Bradley representative or distributor for part numbers and pricing. Repair kits are made to order and have a shelf life of 30 days.

NOTICE! *Do not use strong acid or alkaline chemicals and cleaners to clean Terreon. If these chemicals come in contact with the surface, wipe them off immediately and rinse with soapy water. Avoid contact with harsh chemicals such as paint remover, bleach, acetone, etc. Avoid contact with hot pans and objects.*

Cleaning and Maintenance for Evero

Material Description: Evero Natural Quartz Material is made of bio-based resin, natural quartz and other materials to resist chemicals, stains, burns and impact. Variations in the natural stone color, pattern, size, shape and shade are inherent. Due to these unique characteristics, please expect subtle shade variations when units are installed adjacent to each other.

Routine Cleaning: For regular cleaning, use mild neutral base cleaners.

Stubborn Stains: Remove tough stains, with non abrasive cleaners and pads such as a white Scotch Brite® pad or Magic Eraser. Test on inconspicuous area prior to using the suggested products.

Protecting the Surface: To optimize material performance in high use areas, it is recommended to apply DryTreat Stain-Proof Original or equivalent as needed.

Repair Kits: Evero repair kits are available. Contact your Bradley representative or distributor for part numbers and pricing. Repair kits are made to order and have a shelf life of 30 days.

NOTICE! *Do not use strong acid or alkaline chemicals and cleansers to clean Evero. If these chemicals come in contact with the surface, wipe them off immediately and rinse with soapy water. Avoid contact with harsh chemicals such as paint remover, bleach, acetone, chloride based cleaners, floor cleaners, etc. Avoid contact with hot pans and objects.*

Cleaning and Maintenance for Stainless Steel

Material Description: Stainless steel is extremely durable, and maintenance is simple and inexpensive. Proper care, particularly under corrosive conditions, is essential. Always start with the simplest solution and work your way toward the more complicated.

Routine Cleaning: Daily or as often as needed use a solution of warm water and soap, detergent, or ammonia. Apply the cleaning solution per the manufacturer's instructions and always use a soft cloth or sponge to avoid damaging the finish.

Stubborn Stains: To remove stains from stainless steel use a stainless steel cleaner and polish such as Ball® stainless steel cleaner or a soft abrasive. Always follow the manufacturer's instructions and apply in the same direction as the polish lines.

NOTICE! Never use ordinary steel wool or steel brushes on stainless steel. Always use stainless steel wool or stainless steel brushes.

Fingerprints and Smears: To remove fingerprints or smears use a high quality stainless steel cleaner and polish in accordance with the manufacturer's instructions. Many of these products leave a protective coating that helps prevent future smears and fingerprints.

Grease and Oil: To remove grease and oil use a quality commercial detergent or caustic cleaner. Apply in accordance to the manufacturer's instructions and in the direction of the polish lines.

Precautions: Avoid prolonged contact with chlorides (bleaches, salts), bromides (sanitizing agents), thiocyanates (pesticides, photography chemicals, and some foods), and iodides on stainless steel equipment, especially if acid conditions exist.

NOTICE! Do not permit salty solutions to evaporate and dry on stainless steel.

The appearance of rust streaks on stainless steel leads to the belief that the stainless steel is rusting. Look for the actual source of the rust in some iron or steel particles which may be touching, but not actually a part of the stainless steel structure.

NOTICE! Strongly acidic or caustic cleaners may attack the steel causing a reddish film to appear. The use of these cleaners should be avoided.

Brand Names

Use of brand names is intended only to indicate a type of cleaner. This does not constitute an endorsement, nor does the omission of any brand name cleaner imply inadequacy. Many products named are regional in distribution, and can be found in local supermarkets, department and hardware stores, or through your cleaning service. It is emphasized that all products should be used in strict accordance with package instructions.

Cleaning and Maintenance for WashBar

Wipe top and underside of WashBar with a mild neutral based cleaner. Dry with a soft cloth to avoid micro scratches in the WashBar finish and sensor plates.

Cleaning and Maintenance for Trench Drain

Depending on application and usage, it is recommended that the drain cap and strainer be removed for regular trench drain cleaning 2-3 times a month.

Liquid Soap Recommendations and Dispenser Maintenance

Overview

Quality soap dispensers require good quality soap and periodic maintenance to properly operate. Bradley soap dispensers will provide dependable, consistent operation over the long term when soap with reasonable viscosity and pH levels are used and when a minimal amount of periodic maintenance is performed on the valves. Most soap dispenser problems are caused by soap that is too thick or corrosive, or by a lack of maintenance. Many soaps come in concentrate form which must be diluted with water. Often, the soap is improperly diluted or used straight out of the bottle, which causes clogging and valve failure. If proper soap is being used, valves that have never been cleaned are usually the source of dispensing problems. With proper maintenance and soap, Bradley dispensers will provide long term, trouble free operation.

Viscosity

Soap thickness is determined by a measurement called viscosity. Soap viscosity should be between 100 cps (centipoise) and 2500 cps for all Bradley soap dispensers. Thick soaps flow slower and inhibit the “flushing” action of the valves, which allows the soap to congeal in the valve and cause clogs.

pH Level

The pH (acid) level of the soap should be in the range of 6.5 to 8.5. More acidic soaps (pH levels lower than 6.5) will corrode metal parts (even stainless steel!!) and degrade rubber and plastic components. They will also cause skin irritation. Most inexpensive soaps (typically the pink lotion type) fall into this acidic category and will eventually cause valve failure and metal corrosion.

⚠ CAUTION Base soaps (pH levels higher than 8.5) will cause skin irritation and swelling or degradation of rubber and plastic parts.

Soap Valves

Valves must also be maintained (cleaned) to function properly. At the very minimum, hot water should be pumped through valves periodically to clear out soap residue. Ideally, valves should occasionally be soaked for 30 minutes in hot water or a soap valve cleaning solution. The valve should be pumped at least 20 times while it is soaking to clear any clogs. The soap reservoir should also be flushed with hot water. In cases of extreme clogging, the valve should be disassembled and the parts should be soaked in hot water or cleaning solution to restore proper functioning. Generally, any quality soap meeting the viscosity and pH guidelines above will work well with Bradley soap dispensers. PCMX or Isopropanol based antibacterial soaps (within viscosity and pH limits) will also work with Bradley dispensers. Soaps satisfying these basic guidelines will provide consistent flow and reduce clogs.