

- Tank Type Vertical
- Surface-Mounted
- ADA Compliant

### Product Materials

**BODY:** 20 gauge stainless steel with exposed surfaces in architectural satin finish.

**BACK:** 20 gauge stainless steel; heliarc welded to the body.

**WALL PLATE:** stainless steel.

**SOAP VALVE:** black ABS plastic mechanism.

### Capacity

40 oz. liquid soap.

### Operation

Push-in valve dispenses measured amount of vegetable or coconut oil liquid soaps, synthetic detergents, and antiseptic solutions with less than 5 lbs. of force. Sight gauge indicates refill time. Locked filler top opens with special key provided.

- Bradley liquid soap valves operate best with any vegetable oil or coconut oil hand soap having a 10–15% soap concentration.

### Installation

Verify all rough-in dimensions prior to installation. Secure separate mounting bracket to wall. Slide dispenser into place and secure locking screw through filler hole.

### Guide Specification

Surface-mounted liquid soap dispenser shall be fabricated of 20 gauge satin finish stainless steel. Dispenser shall have completely concealed mounting, vandal-resistant filler hole cover and sight gauge. Push-in corrosion-resistant liquid soap valve. Capacity: 40 oz. liquid soap. Requires less than 5 lbs. of force to dispense soap.

**Overall dimensions:** 4<sup>13</sup>/<sub>16</sub>"W x 8<sup>3</sup>/<sub>16</sub>"H x 2<sup>7</sup>/<sub>8</sub>"D.

### ADA Compliant

- Consult local and national accessibility codes for proper installation guidelines.
- Conformity and compliance to local and national codes is the responsibility of the installer.

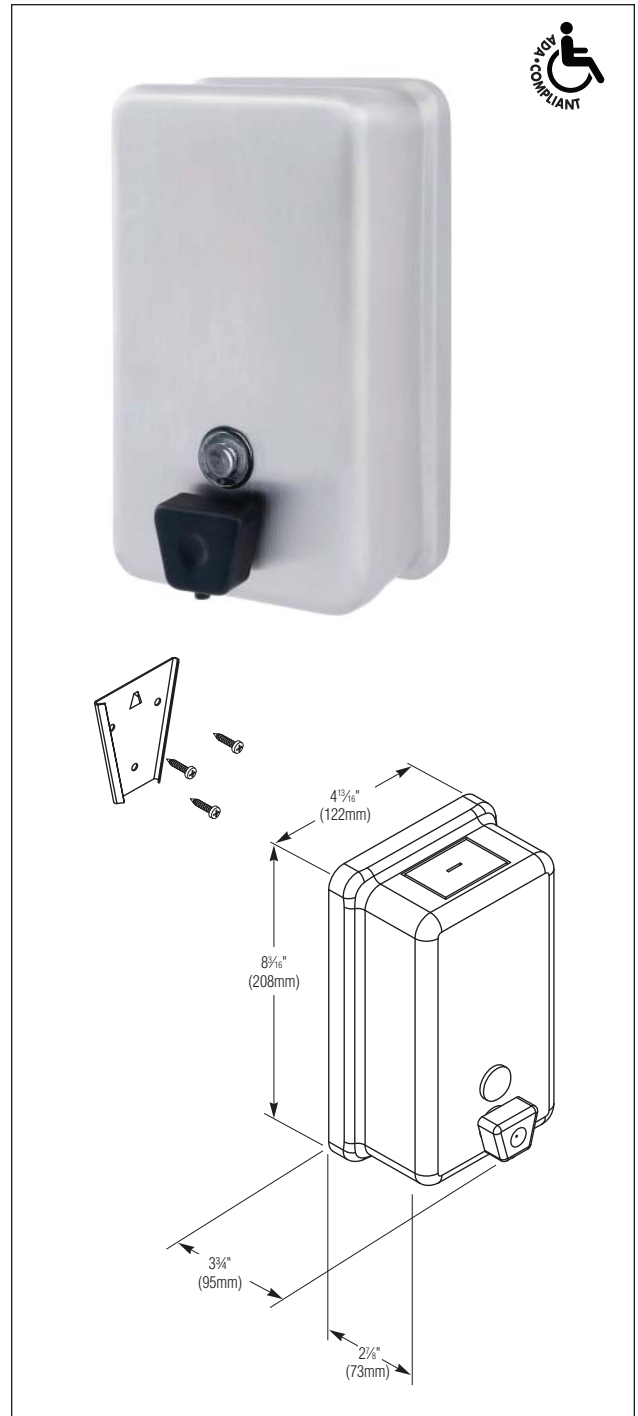

Washroom Accessories  
Document No. 8692