

# Installation

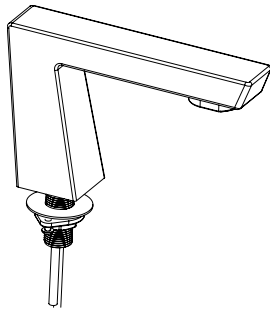
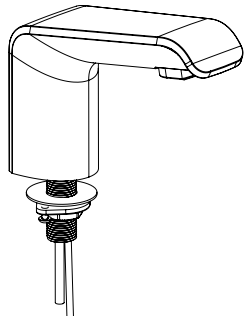
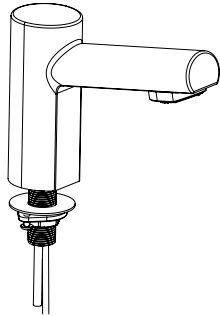
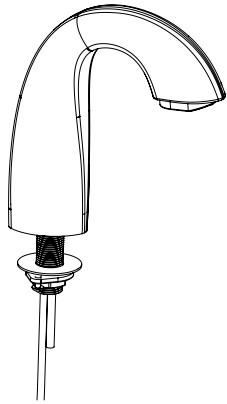

[Escanee o haga clic en el código para ver la Guía de instalación \(español\)](#)

**Verge™ Faucet - Crestt Series (S53-3100)**

**Verge™ Faucet - Metro Series (S53-3300)**

**Verge™ Faucet - Linea Series (S53-3500)**

**Verge™ Faucet - Zen Series (S53-3700)**

## Table of Contents

Safety Information . . . . .	2
Supplies Required . . . . .	2
Dimensional Information . . . . .	3
Faucet Components . . . . .	4
Mount Faucet on Deck . . . . .	5
Connect Water and Electrical Supply . . . . .	6
Adjust Temperature with Running Water . . . . .	7
Test Unit . . . . .	7
Multi-Faucet Wiring . . . . .	8
Adjusting the Control Module . . . . .	8
Troubleshooting – Solenoid Valve . . . . .	9
Troubleshooting – Thermostatic Mixing Valve . . . . .	9
LED Indicators . . . . .	9



**Read the instructions in this manual before beginning installation. Save these instructions and refer to them for inspection, maintenance, and troubleshooting information.**

For questions regarding the operation, installation or maintenance of this product, visit [bradleycorp.com](http://bradleycorp.com) or call 800.BRADLEY (800.272.3539).

Product warranties and parts information may also be found under “Resources” on our website at [bradleycorp.com/customerservice/warranty](http://bradleycorp.com/customerservice/warranty).



## Safety Information

### Warning

Make sure that all water supply lines have been flushed and then completely turned off before beginning installation. Debris in supply lines can cause valves to malfunction.

### Caution

A DC plug-in adapter (supplied by Bradley) should be used in conjunction with the Bradley supplied faucets. The DC plug-in adapter supplied by Bradley is 6V DC regulated. Direct connection to 120V/220V 50/60Hz could result in personal injury and will damage the sensor.

### Important

Separate parts from packaging and make sure all parts are accounted for before discarding packaging material. If any parts are missing, do not begin installation until you obtain the missing parts.

When the faucet is mounted on a fixture with a stainless steel bowl, it is recommended that the bowl have a satin finish rather than a mirrored or highly polished finish.

## Supplies Required

- 120V/220V 50/60Hz power source when using Bradley supplied 120V AC/6V DC plug-in adapter
- Tempered hot and cold supply piping and male fittings to solenoid valve
- Pipe fittings, pipe sealant as required

# Dimensional Information

(mm)

3100 Crest Series

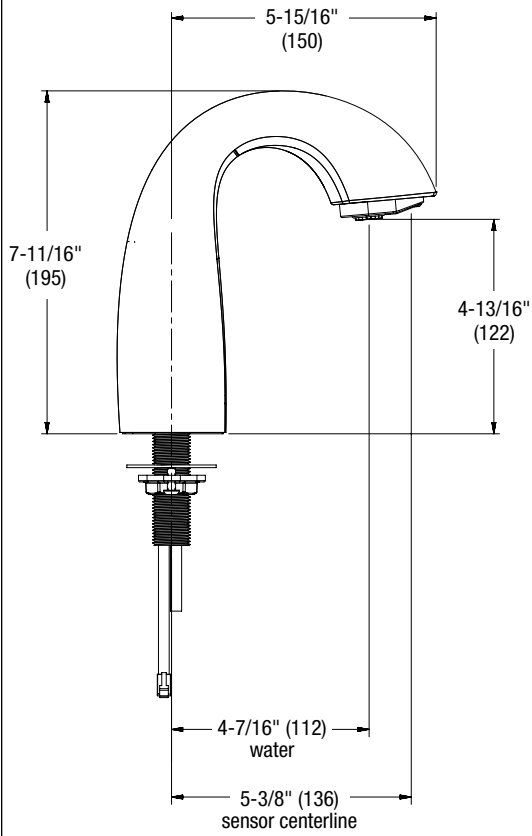

3300 Metro Series

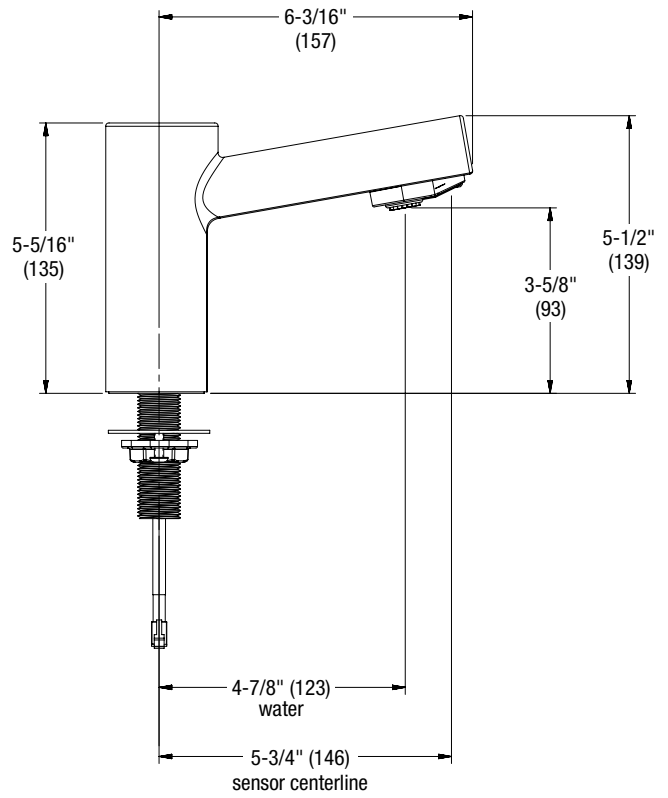

3500 Linea Series

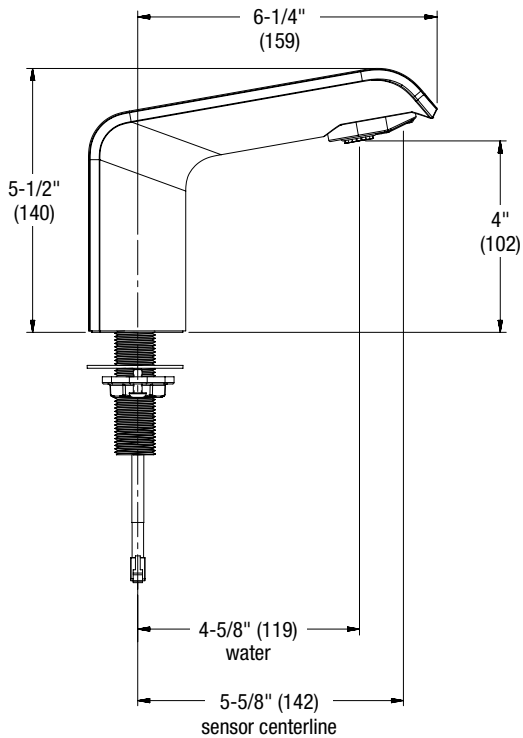

3700 Zen Series

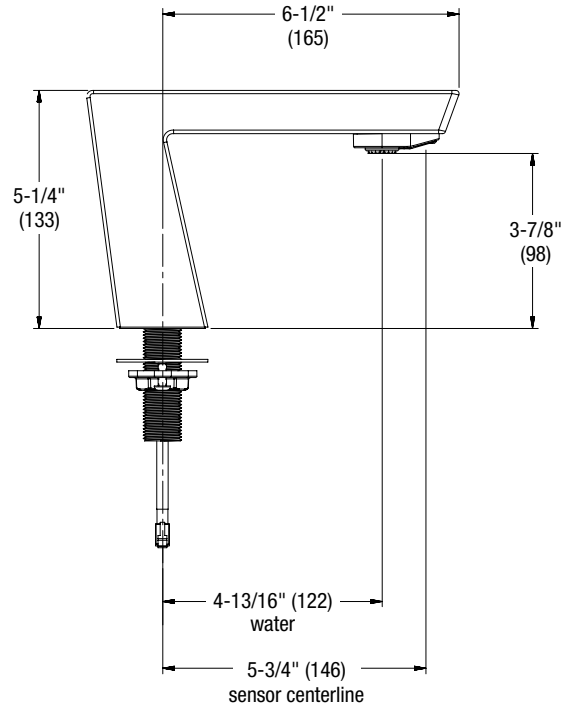

# Faucet Components

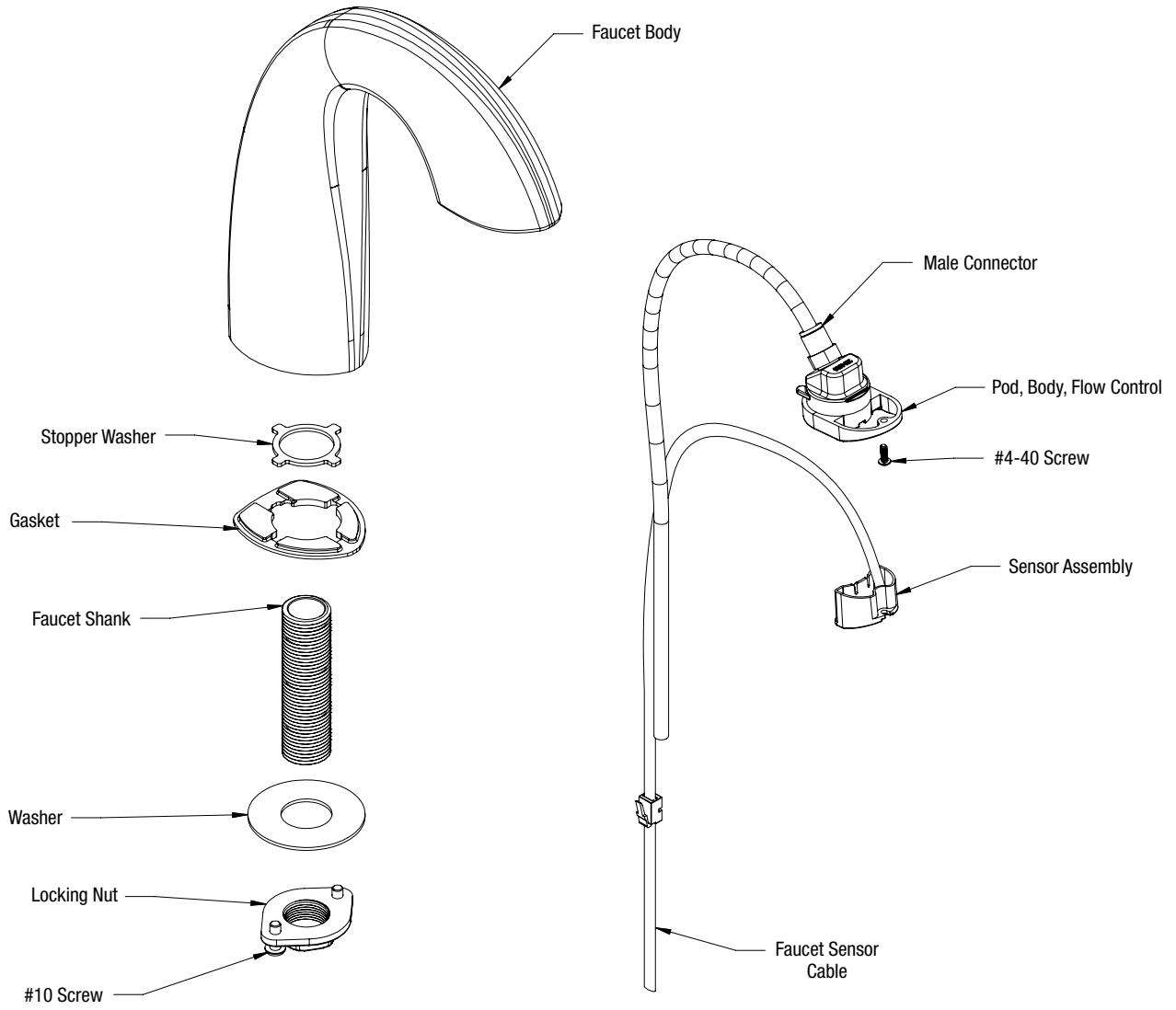

# 1 Gasket Installation

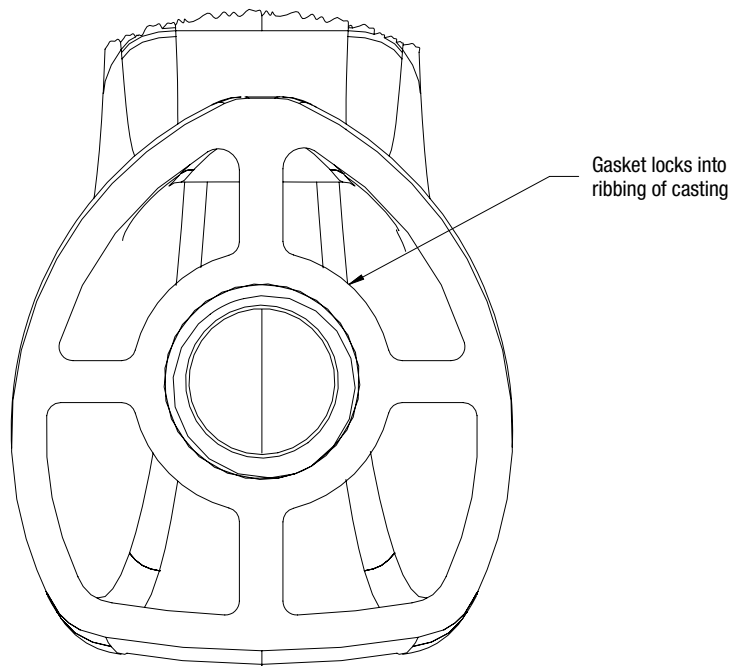
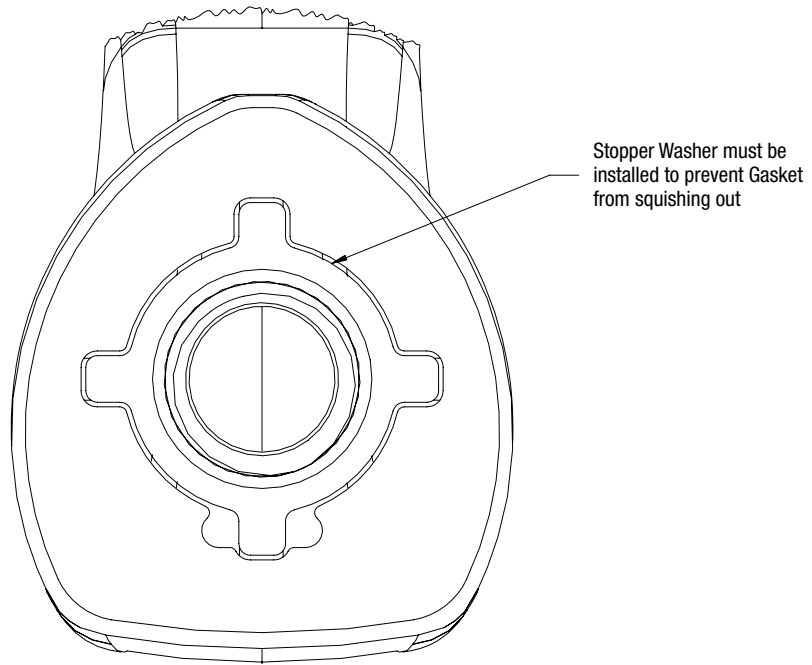

## 2 Mount Faucet on Deck

- When installing a faucet to a new deck installation, it is advisable to assemble faucet to deck when deck is on hard floor surface prior to deck attachment to wall for ease of assembly.
- Before drilling, note that the minimum mounting distance between a Verge faucet and Verge soap dispenser is 6".

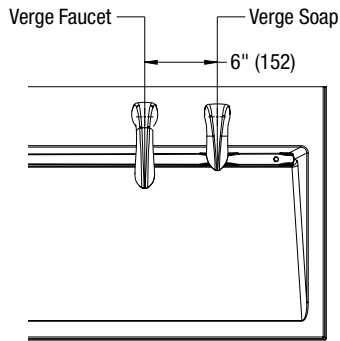

**A** Drill holes in deck to the size and position for your faucet configuration.

**B** Attach faucet securely to deck.

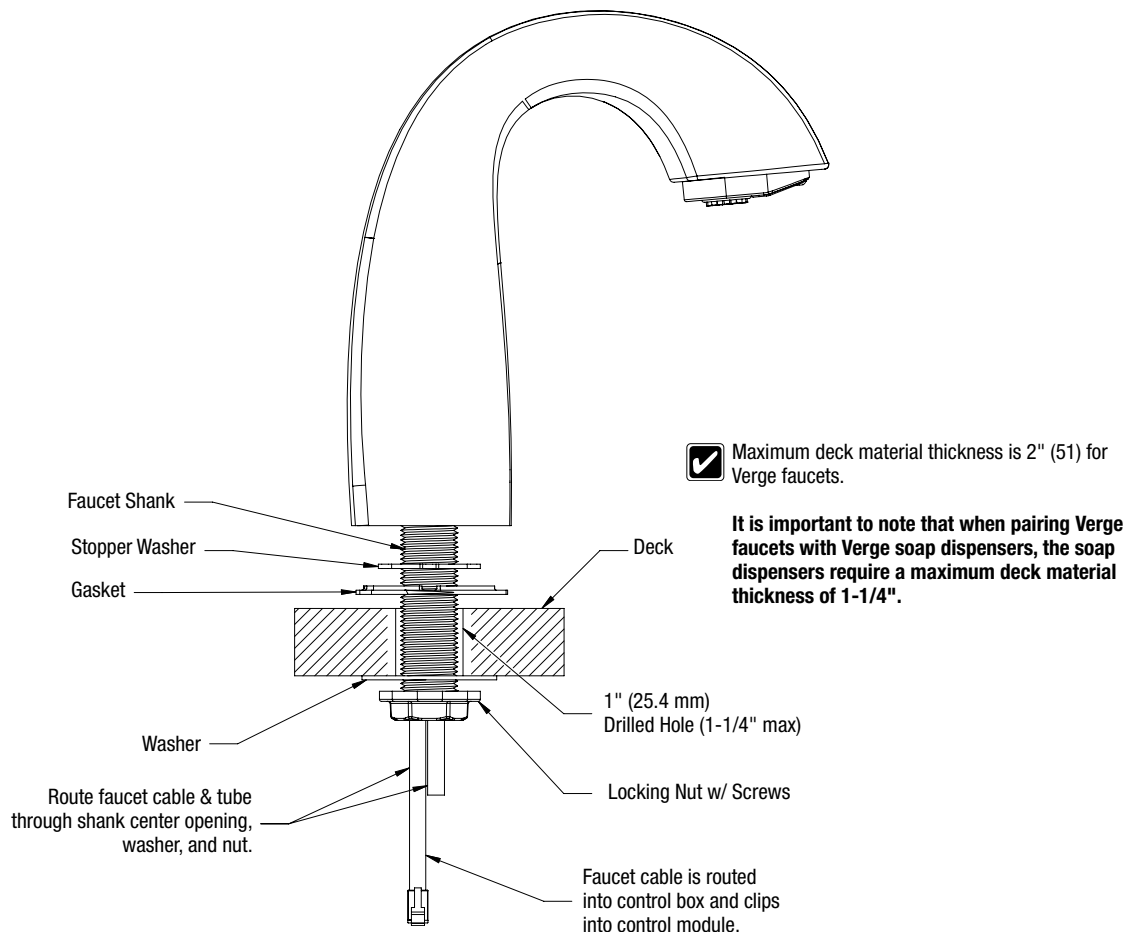

### 3 Connect Water and Electrical Supply

#### Thermostatic Valve Assembly and Tempered Line

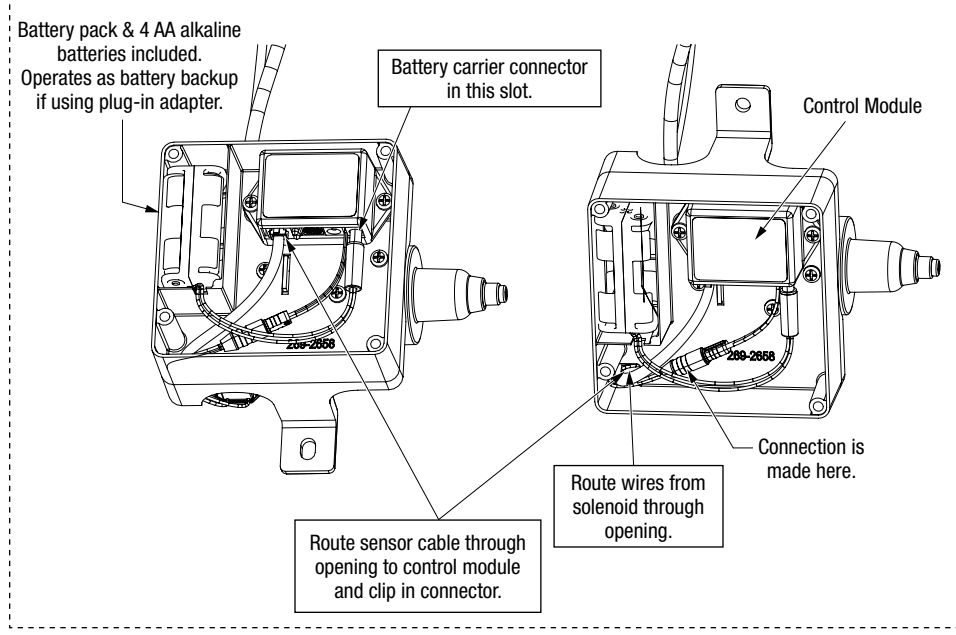
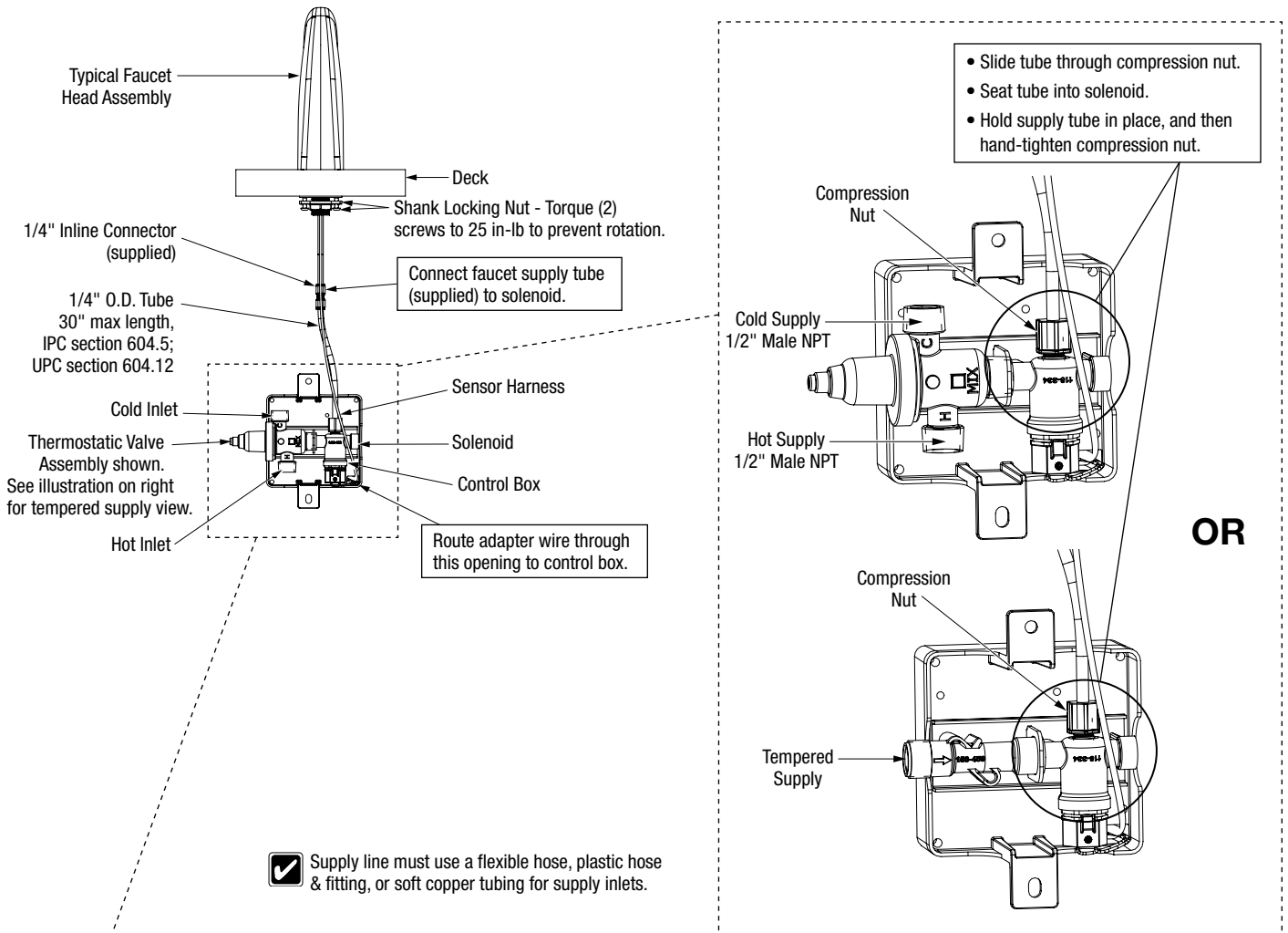

## 4 Adjust Temperature with Running Water



*This step only applies for units equipped with a TMA Navigator Mixing Valve.*



*This valve is NOT factory preset. Upon installation, the temperature of this valve must be checked and adjusted to ensure delivery of a safe water temperature. Water in excess of 110°F (43°C) may cause scalding.*

**A** Loosen cap screw about 1/4" (4-6 turns) and lift up cover (do not remove).

**B** Using cover, turn cartridge gently until desired water temperature is reached. Do not turn past stops as this may damage unit. Push cover down and tighten screw.

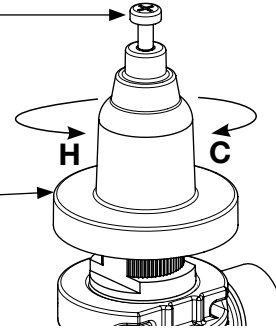

## 5 Test Unit DO NOT SKIP THIS STEP!!!



*This step only applies for units equipped with a TMA Navigator Mixing Valve.*

**A** Shut the hot water inlet off by closing hot water inlet valve. While the hot water supply is turned off, check to make sure the cold water flow is reduced. If the cold water is reduced properly, reopen the hot water supply.



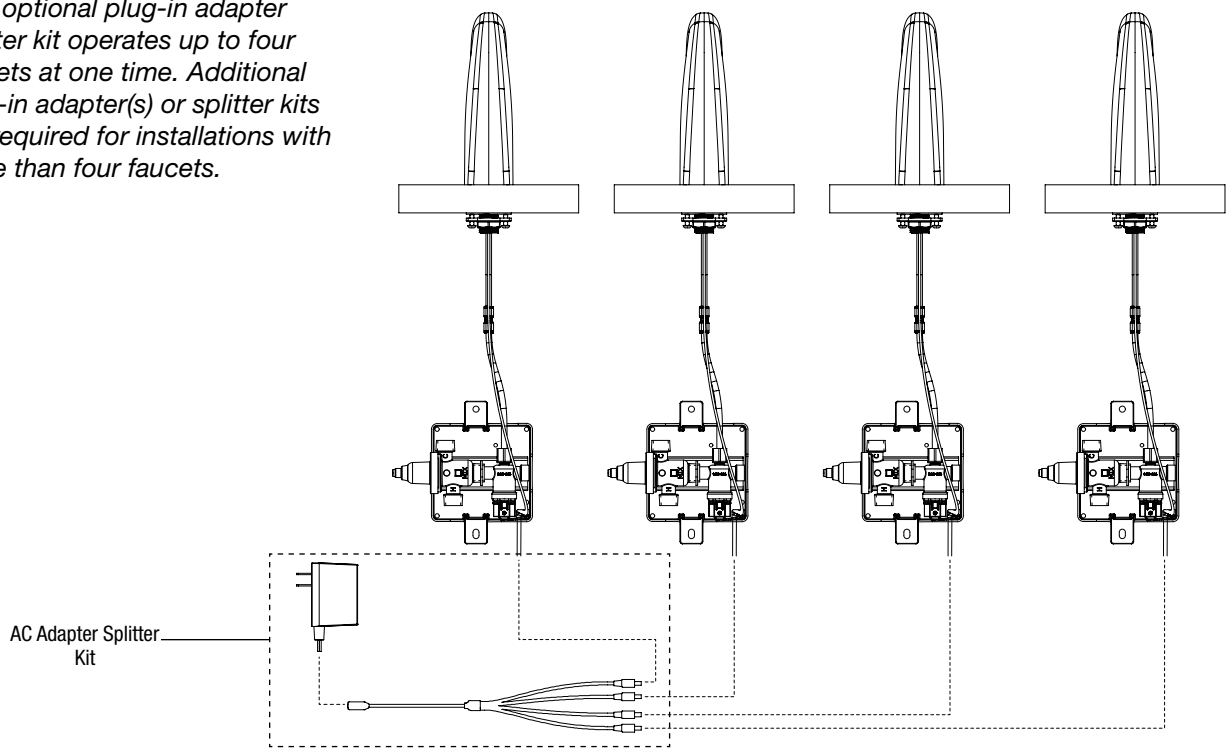

**B** Shut the cold water inlet off by closing the cold water inlet valve. While the cold water supply is off, check to make sure that the hot water flow has shut down.

## Multi-Faucet Wiring

- 
 One optional plug-in adapter splitter kit operates up to four faucets at one time. Additional plug-in adapter(s) or splitter kits are required for installations with more than four faucets.



## Adjusting the Control Module

- 
 The control module is set at the factory with the selector switch in position 5. This provides a 11 second run time.
- 
 The 24 hour flush function will activate water flow for a period of 60 seconds any time there has been no activation within the past 24 hours. This function is used to help clear stagnant water from the plumbing system and can provide some measure of prevention against the formation of bacteria in supply pipes.
- 
 Switch position 1 allows a manual override of the solenoid to allow the solenoids to flow continuously.
- 
 Switch positions 0, 2, and 3 do not apply to this product.

**A** To adjust the control module to a different time out period, turn the selector switch to the desired time out setting (4 through 9 for no flush, A through F for 24 hours flush) as indicated on the module label.

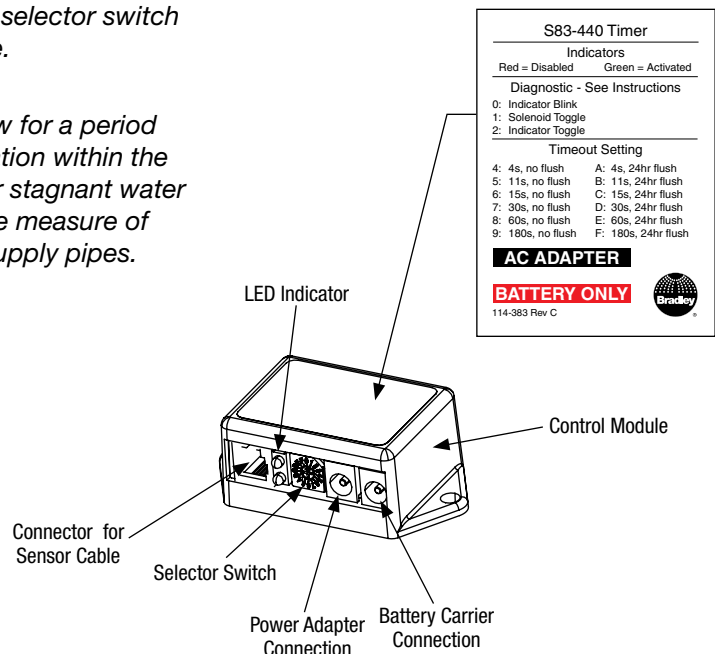

## Troubleshooting – Solenoid Valve

Problem	Cause	Solution
Faucet fails to shut off and drips.	The cartridge valve is defective.	Replace cartridge with part number S27-352A.
Faucet fails to turn on.	A failed valve or loose electrical connection to the connectors.	1. Repair loose connection. 2. If possible, determine whether sensor, power adapter or valve is defective by swapping parts with an adjacent faucet. Replace defective part.
Faucet doesn't activate.	Blocked sensor.	1. Clean sensor lens with soft, damp cloth. 2. Unplug power supply or remove batteries. 3. Reconnect power supply or install new batteries.

## Troubleshooting – Thermostatic Mixing Valve

Before attempting to troubleshoot the valve or disassemble the components, check for the following conditions:

- If stop valves are used, make sure that they are fully open.
- Make sure that the hot and cold inlet pipes are connected properly, and that there are no cross-connections or leaking stop valves.
- Check the hot water heater output to make sure that it is at least 10°F above the set temperature.



*Close the appropriate shut-off valves prior to disassembly and reopen valves after inspection and repair is complete.*

Problem	Cause	Solution
External leaks.	Damaged cartridge or O-rings.	Replace cartridge with part number 269-1927.
Improper water temperature or temperature fluctuation.	Hot water supply is not 10° above desired set point.	Increase hot water supply temperature.
	Valve temperature is not properly set.	Adjust the temperature as shown on page 4 step 3.
Limited water flow.	Dirt and debris have built up in the valve or strainer.	1. Check to make sure both hot and cold supplies are connected to the Navigator mixing valve and that they have water flow. 2. Remove cover and U-clip. Remove the cartridge and clean the strainer. It is not required to grease cartridge, however if desired, use silicone grease only. Do not use grease on check valves.

## LED Indicators

LED Indicator	Cause	Solution
Flashing red LED.	Low battery.	Replace 4 AA alkaline batteries and activate faucet.
Rapid red flashing LED.	Blocked sensor communication.	Power cycle.
Green constant flashing LED upon initial startup.	Debris on plastic cover.	Clean plastic cover.
Red flashing LED upon initial startup.	Hardware issue with TOF sensor.	Power cycle.