

SENSOR-ACTIVATED, DECK MOUNT FOAM SOAP DISPENSER

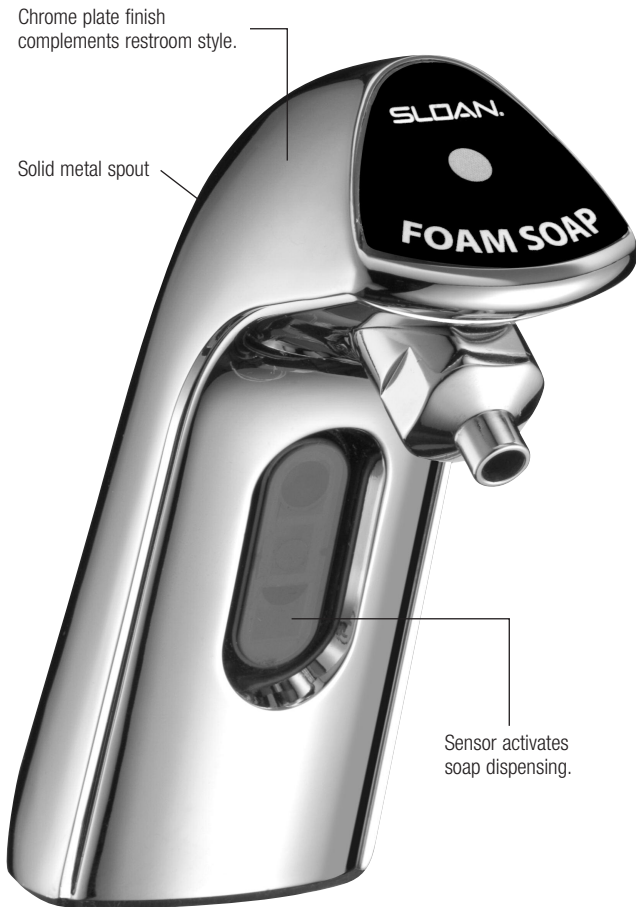

The SJS-1750 sensor activated foam soap dispenser is the next evolution in dispenser technology. It uses a refill bottle that simplifies replacement and reduces waste. Its sensor technology offers hands-free operation by delivering a pre-measured foam soap application "on demand."

- Sensor-technology activates foam soap dispensing
- Hand-free operation promotes hygiene and eliminates cross contamination
- Easily attaches to deck surface
- Low soap level indicator
- 110 VAC

The contemporary design complements all restrooms.

Product Number: SJS-1750

Product Code: 7000015

Color: Chrome

Size: W 1.65" x D 4.25" x H 4.00"
(W 42 mm x D 108 mm x H 102 mm)

Quantity/pack: 1

Quantity/case: 6

Refills:

Product No.	Description	Order No.
SJS-1751	Sensor Deck-Mount Foam Soap	5700751
SJS-1751-3	Sensor Deck-Mount Foam Soap (Fragrance Free)	5700754
SJS-1751-4	Sensor Deck-Mount Foam Soap (Rose)	5700755

SJS-1750

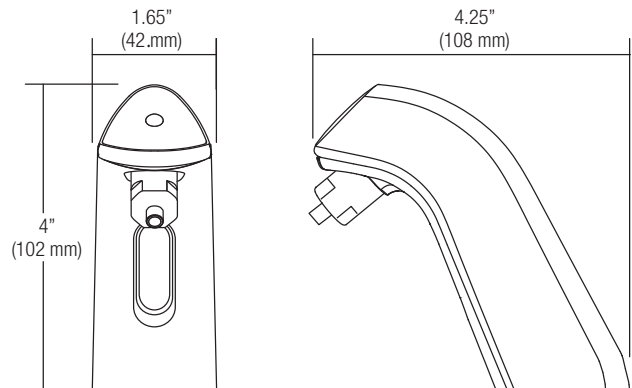
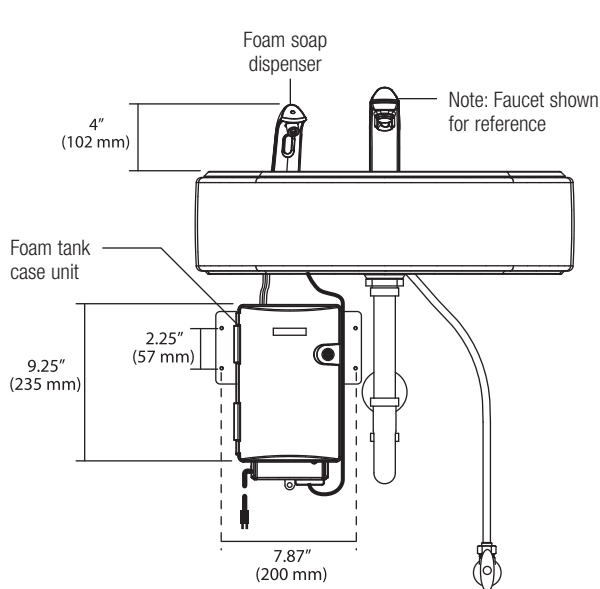

The information contained in this document is subject to change without notice.

SLOAN®

Sloan HEALTHMINDER™ Products
10500 Seymour Avenue
Franklin Park, IL 60131-1259
Phone: 877-652-6726
Fax: 800-447-8329
www.sloanvalve.com