

► Description

Double Station Solid Surface Lavatory System Equipped with Sloan OPTIMA® Electronic Sensor Technology.

► Specifications

Double Station Lavatory System with Sloan Electronic Sensor Technology with the following features:

- Sink must have the Easy Access integrated head for ease of maintenance and installation. The Easy Access integrated head must house the solenoids, shut-off valves, IR Sensor, electronic modules and be pre-plumbed as well as be accessible from the top of the sink.
- Sloan Optima Electronic Sensors for hands free point of use activation
- Water Conserving, touch free, on-demand sensors detect users hands at the point of use preventing unintentional activations
- Recessed sensors are concealed from user, reducing damage and vandalism
- Dual protected integrated overflows
- 1 1/4" chrome plated brass drains with grid strainers
- Optional top filled gravity fed manual Soap Dispensers
- Basin, Integrated Head and Cabinet End Caps constructed of durable SloanStone solid surface material
- Concealed Cabinet Frame constructed of heavy duty 16 gauge type 304 stainless steel accented with 18 gauge brushed stainless steel Front Panel
- No visible fasteners or obvious access points
- Below deck Thermostatic Mixing Valve, standard
- ADA and TAS lavatory Rim Height Standards achieved in a single design
- Aesthetically pleasing soft contoured one-piece continuous Basin
- Top Access Lid Secured by Ultra Heavy Duty Latch Mechanism with Recessed Allen Key Activation. T-handle Allen wrench standard

► Variations

- MSD Manual Soap Dispenser
- BSD Manual Soap Dispenser with Lid Mounted Fill Cap

► Sloan Optima® Electronics feature:

- Sloan Optima Sensor Technology for reliable performance
- Troubleshooting LED Indicator Lights
- Brass Solenoid with serviceable "Y" Strainer Filter
- Stainless Steel vandal resistant Spouts
- Water saving 0.5 gpm/1.9 Lpm max. Aerator
- Hardwire powered

► Code Number

16012603

► OPERATION

OPERATION

As the user's hands enter the beam's effective range, the beam is reflected back into the sensor receiver and activates the solenoid valve allowing water to flow from the spout. Water will flow until user's hands are removed or until the time out limit is reached.

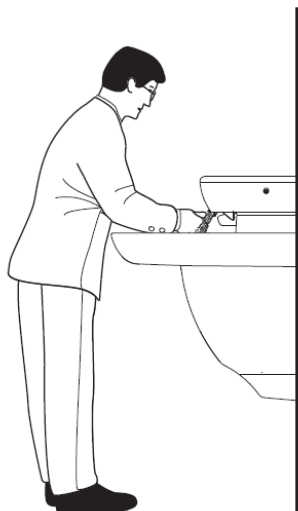

► The New SloanStone™ Lavatory System — The Perfect Match

The dependability of Sloan electronics combined with the durability of our SloanStone solid surface material creates the ultimate in vandal resistant lavatory systems with a unique designer style.

Having all the serviceable components accessible from the top, including a water shut-off valve, all the electronics, sensors, solenoids and soap components, gives SloanStone sinks the simplest installation and maintenance available. All of this is kept secure from prying hands by a recessed screw and bracket mechanism on each side of the head, which can be loosened with the supplied T-handle wrench. Therefore, there are no visible fasteners on the unit to invite would-be vandals. The infrared sensors are also recess mounted in a stainless steel plate behind the aerator spray head keeping them out of sight of the user, virtually eliminating potential damage to the sensor windows and making this a true water conserving on-demand unit.

"A heavy gauge brushed stainless steel front panel conceals the drain lines, supply stops and thermostatic mixing valve

► Compliance & Certifications



► SloanStone® Lavatory Sinks are:



► Sloan Optima Electronics are:



This space for Architect/Engineer Approval

► SLOANSTONETM COLORS

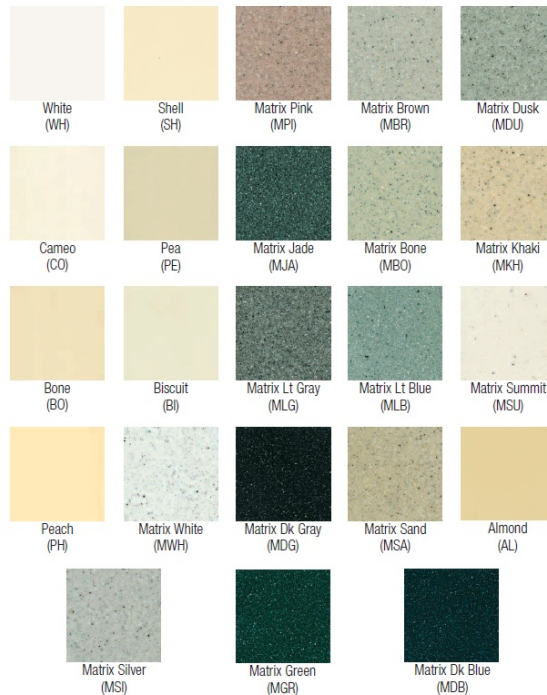

Expanded color options available at: www.sloanvalve.com.
For in stock availability and quick-ship options please contact your local Sloan representative.

► ROUGH-IN

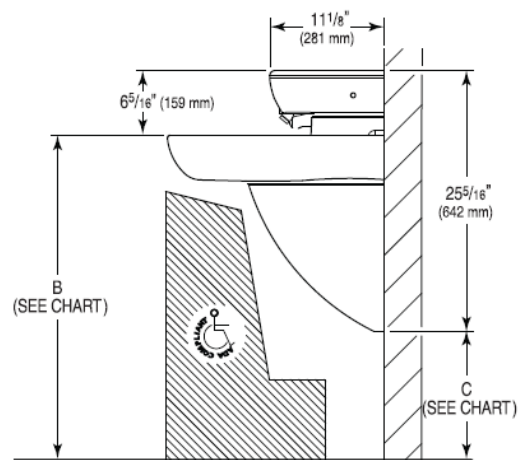
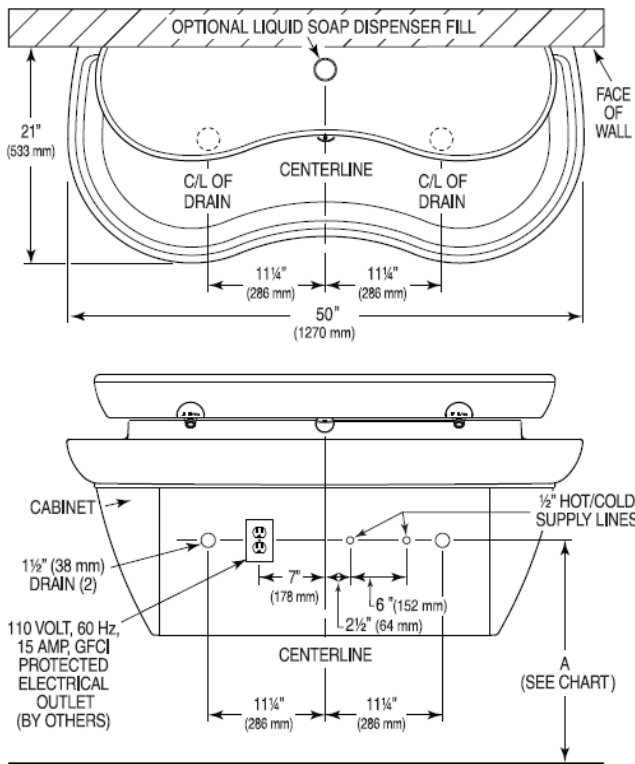

† When no mirror is required above the basin.
For T.A.S. compliant installations requiring a mirror above the basin, use ELS-72000 products.

Consult local electrical codes for the mounting location of the 110/24 VAC Class 2 transformer.

For additional technical information, contact the Sloan Installation Engineering Department at 1-888-SLOAN-14 (1-888-756-2614) or techsupport@sloanvalve.com.

VARIABLE MOUNTING HEIGHT CHART				
⦿	DIMENSION DESCRIPTION	T.A.S. † AGES 4-10	T.A.S. † AGES 11-15	A.D.A. STANDARD
A	ROUGH-IN	20-1/2" (521 mm)	22-1/2" (572 mm)	24" (610 mm)
B	RECOMMENDED RIM HEIGHT	29-7/8" (759 mm)	31-7/8" (810 mm)	33" (838 mm)
C	FLOOR CLEARANCE	10-7/8" (276 mm)	12-7/8" (327 mm)	14" (356 mm)