



AMERICAN SPECIALTIES, INC.

441 Saw Mill River Road, Yonkers, NY 10701 (914) 476-9000

MODEL No: 3451

ISSUED: 1-87

REVISED: 9-04

SWING-UP GRAB BAR

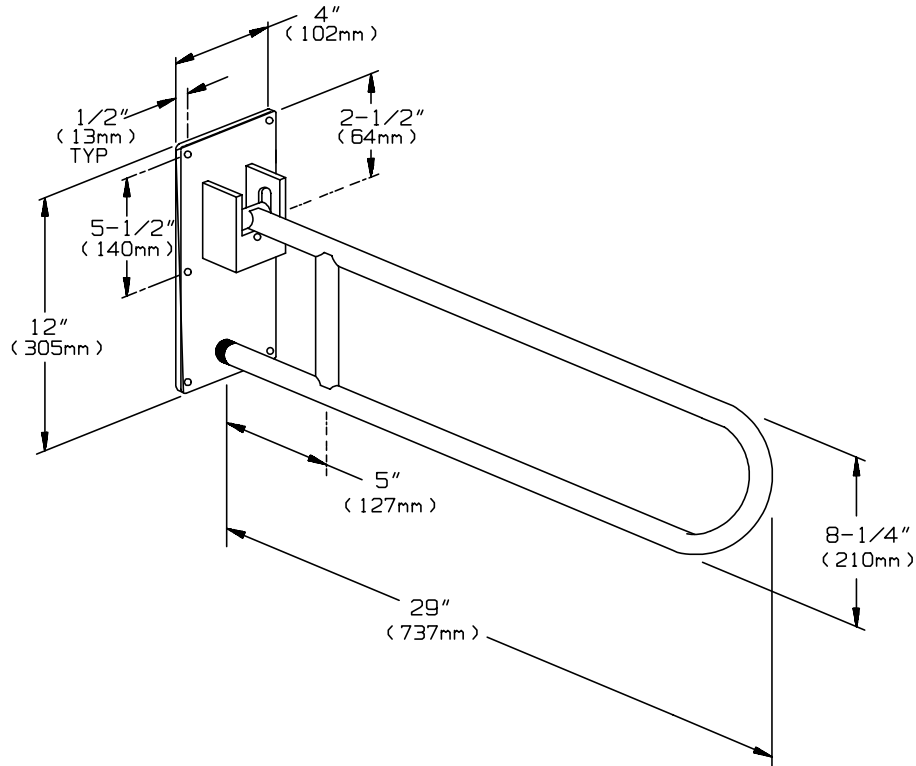

SPECIFICATION

Swing-Up Grab Bar shall be fabricated of alloy 18-8 stainless steel type 304. Grab bar tubing shall be 1-1/4" (32mm) dia. 18 gauge. Mounting bracket shall be 7 gauge plate with six (6) 5/16" (8mm) dia. mounting holes provided and shall have 1-1/4" (32m) dia. x 3/16" (5mm) wall tubing hinge riding on solid bar axle with twin torsion-spring counter balance. All exposed surfaces shall be N^o 4 satin finish. Structure shall be of welded construction. All exposed edges and corners shall be radiused and burr free. Vertical position gravity lock with manual release shall be provided. Tamper resistant set screw shall be provided to allow owner to lock grab bar in vertical position. Internal mechanisms shall be captive and suitable for heavy duty service. Grab bar shall be operable with only one hand.

Swing-Up Grab Bar shall be Model N^o 3451 as manufactured by American Specialties, Inc., 441 Saw Mill River Road, Yonkers, New York 10701-4913

INSTALLATION

This unit is surface mounted. Installer/construction contractor must provide concealed anchor plate or blocking as specified in construction documents or as required by local building codes prior to wall finishing. Fasten wall plate to concealed anchor or blocking plate with appropriate hardware. See "STRENGTH" section below. Note that concealed mounting plates or anchors and hardware are not supplied with this product and must be specified separately (for anchor plate add line item 3940). Ensure that mounting configuration complies with local building codes.

STRENGTH

ASI grab bars are designed to meet and exceed ADAAG requirements as published in CABO/ANSI A117.1-1992 and CFR 28 Part 36, Federal Register Vol. 56 N^o 144, 26 July 1991, that fabricated product shall be of adequate strength to support a load of 250 pounds (113.4 kg). Mounting to the wall is a critical part of the system to meet this requirement. To withstand the shear, tension or pull-out, and torsion loads generated by the maximum loading, the fastener system must be adequately sized.

OPERATION

Swing-Up Grab Bar is manually lowered to horizontal position for support and raised for departure or arrival. Gravity lock prevents grab bar from dropping from the vertical position, and must be manually released to lower grab bar. Lock does not affect raising bar from horizontal and automatically locks bar when bar is returned to vertical storage position.

OPTIONS AVAILABLE

For integral toilet tissue roll holder specify option -25. For non-slip gripping surface add suffix -P (peened).

Accessory Specialties

AMERICAN DISPENSER

Desert Ray Products

WATROUS INC.